

LIGHT SKY

www.lightsky.com.cn

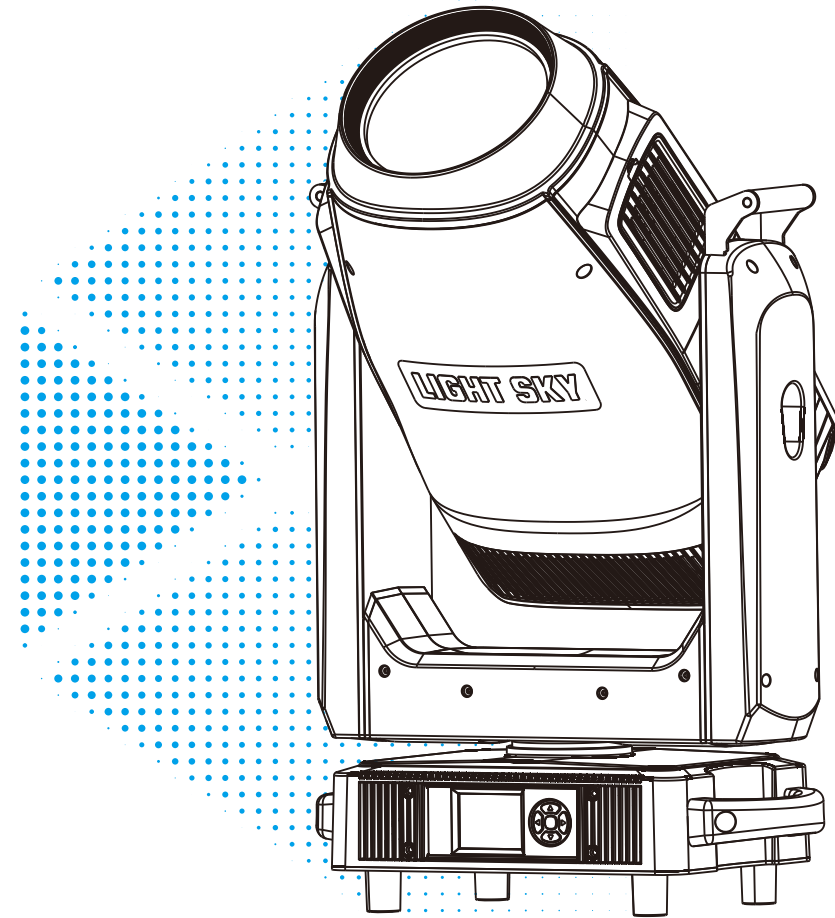

SUPER SCOPE COLOR User Manual

Please read the instruction carefully before use

Fly Dragon Lighting Equipment Co., Ltd.

Add : NO.4 JINGNENG ROAD 1, HUADU DISTRICT, GUANGZHOU, CHINA.
Tel : 020-61828288 Fax : 020-61828188 Postal Code : 510820
Email : flydragon@lightsky.com.cn



Social Media



LIGHT SKY Wechat

CONTENTS

| | |
|--|----|
| 1、 Safety Instructions..... | 2 |
| 2、 Technical Specifications..... | 4 |
| 2.1、 Attachment And Size..... | 7 |
| 3、 Prism/Effect/Pattern..... | 9 |
| 3.1、 Replacing Rotating Gobos | 10 |
| 4、 Control Panel..... | 13 |
| 5、 Connection and control..... | 14 |
| 5.1、 Power supply connection | 14 |
| 5.2、 DMX 512 Connection..... | 15 |
| 6、 How To Set The Unit..... | 16 |
| 6.1、 Main Function | 16 |
| 6.2、 Channel Setting | 19 |
| 6.3、 Address Setting | 19 |
| 6.4、 DMX 512 Configuration | 20 |
| 7、 Electrical Connection Diagram | 34 |
| 8、 Troubleshooting | 35 |
| 9、 Fixture Cleaning | 37 |
| 10、 Duty exonerative and copyright protectio | 37 |

Congratulations on choosing our company product! We thank you for your custom.

- Please keep in mind that this product, like other products of the company, adheres to the concept of people-oriented design and manufacture, and takes product quality as the foundation.
- We put the interests of customers first, and do our best to meet customer requirements.
- Please read this instruction manual carefully and keep it for future reference. In the case of fully understanding the product information, strictly abide by theUse the instruction manual to ensure that the product is installed, used and serviced correctly and safely.
- Our company is not responsible for any damage to lamps or other performance due to personal failure to follow the instructions during installation, use and maintenance.responsibility.
- Our company reserves the right to modify the manual at any time and without prior notice.

1.Safety Instructions



WARNING

Please read the instruction carefully which includes important information about the installation, usage and maintenance.

Please keep this User Manual for future consultation. If you sell the unit to another user, be sure that they also receive this manual.

The following symbols are used to identify important safety information on the product and in this manual:

| | | | | | | | | |
|--|--|---|---|---|---|---|---|--|
| | | | | | | | | |
| WARNING! Safety hazard. Risk of severe injury or death. | WARNING! Refer to manual before installing, powering or servicing. | WARNING! Hazardous voltage. Risk of severe or lethal electric shock. | WARNING! Fire hazard. | WARNING! Burn hazard. Hot surface, not touch. Do not touch | WARNING! Risk of eye injury. Safety glasses must be worn. | WARNING! Risk of hand injury. Safety gloves must be worn. | WARNING! Avoid direct eye contact | |
| | | | | | | | | |
| DANGER! Applies only to luminaires directly mounted on surfaces of non-combustible materials | DANGER! Do not discard Trash can | DANGER! Mark of ground | DANGER! Replace all shatter shields | DANGER! Take a short distance from the object to be photographed (meters) | DANGER! Rated maximum ambient temperature | DANGER! Indoor use only | DANGER! Do not point the lens towards the sun or strong light | DANGER! Operation not allowed during runtime |

Important:

Damages caused by the disregard of this user manual are not subject to warranty. The dealer will not accept liability for any resulting defects or problems.

- Unpack and check carefully to ensure that there is no transportation damage before using the unit.
- This product is for indoor use only. Use only in a dry location.
- Do install and operate by qualified operator.
- The light source in this luminaire should be replaced by the manufacturer or its service agent or a similarly qualified person, always cut off the power supply before replacing he light source.
- Do not allow children to operate the fixture.
- The unit must be installed in a location with adequate ventilation, at least 20cm from adjacent surfaces.
- Be sure that no ventilation slots is blocked, otherwise the unit will be overheated.

- Before operation, ensure that you are connecting this product to the proper voltage in accordance with the specifications in this manual or on the product's specification label.
- It's important to ground the yellow/green conductor to earth in order to avoid electric shock.
- Minimum ambient temperature Ta: -10°C. Maximum ambient temperature Ta: 45°C.
- Do not operate this product at a lower or higher temperature.
- Do not connect the device to any dimmer pack.
- When the lamp is running, do not place combustible objects next to it. The shortest distance between the device and inflammable and explosive objects or materials is 0.5m.
- Make sure the power cord is not crimped or damaged; replace it immediately if damaged.
- Unit's surface temperature may reach up to 75°C. Do not touch the housing bare-handed during its operation.
- Avoid any flammable liquids, water or metal from entering the unit. Once it happens, cut off the mains power immediately.
- Do not operate in a dirty or dusty environment. Do clean the fixture regularly.
- Do not touch any wire during operation as there might be a hazard of electric shock.
- Avoid entanglement of the power cord with other wires.
- The minimum distance to objects/surface must be more than 3 meters.
- In the event of serious operating problem, stop using the unit immediately.
- Never turn on and off the unit time after time.
- The housing, the lenses, or the ultraviolet filter must be replaced if they are visibly damaged.
- Do not open the housing as there are no user serviceable parts inside.
- Do not attempt to operate this unit if it becomes damaged. Do not attempt any repairs yourself. Repairs carried out by unskilled people can lead to damage or malfunction. Please contact the nearest authorized technical assistance center if needed.
- Disconnect this product from its power source before servicing.
- Do use the original packaging if the device is to be transported.
- Avoid direct eye exposure to the light source while the product is on.
- Do not operate this product if you see damage on the housing, shields, or cables. Have the damaged parts replaced by an authorized technician at once.

Installation:

The luminaire must be securely fastened to the quick-lock hook with screws to prevent vibration or slipping during operation. The supporting structure must be able to withstand 6 times the weight of the luminaire. Additionally, a safety cable must be installed that can endure 30 free-fall drops from 300mm without failure. Installation should only be performed by qualified professionals, and the luminaire must be mounted in an area inaccessible to unauthorized personnel or away from pedestrian traffic.

2. Technical Specifications

OPTICS

- Light source: 600W five color LED module (RGBAL)
- Field Angle: 5.9 ° -52 °
- Optical lens: coated with high anti reflective film, diameter 180mm
- Color temperature: 2700-8000 K
- Color rendering index: Ra≥95
- Illuminance: 12500 lx @10m
- Whole lamp output luminous flux: 17600 lm
- LED source life expectancy: 50000 h (*LED source life depends on several factors, including but not limited to: environmental conditions, control dimming, power supply and voltage, switching cycle, fixture mode, etc.)
- Utilizes the iCC™ Color Calibration System.

COLOUR

- 165 electronic color chips with rich colors
- Virtual CMY
- Virtual CTO

PATTERN

- 2 rotating pattern disks, 14 glass pattern pieces, with a dynamic stacking effect that can be plugged and replaced to achieve self rotation, flowing water, and shaking effects,
- Rotating disk A: 7 types of glass patterns+white circles, pattern piece outer diameter 26.9mm, pattern piece inner diameter 21.5mm.(When cutting and imaging patterns, using pattern disc A yields better results).
- Rotating disk B: 7 types of glass patterns+white circles, pattern piece outer diameter 26.9mm, pattern piece inner diameter 21.5mm.
- Dynamic Effect Disk
- Eight way cutting: 4 gratings achieve fast and smooth cutting, and the eight cutting directions and angles can be individually controlled. Each single grating can achieve complete light closure, and the entire cutting module can rotate $\pm 55^\circ$.

EFFECT

- Octagonal prism, capable of bidirectional rotation.
- Heavy atomization+light atomization, can be independently switched and stacked.
- Equipped with electric aperture, 5-100% linear adjustment, with macro functions and multi effect changes.
- Electronic dimming, 0-100% linear dimming, uniform light spot.
- Electronic strobe speed is 1-25 times/second
- LED refresh rate: 1000Hz~25K Hz

CONTROL AND PROGRAMMING

- Control channels: 60CH, 35CH, 64CH, 49CH, see channel table for details
- Protocol: Standard DMX512 protocol, RDM protocol, Art-Net protocol, sACN protocol.
- Data connection: Three core or five core signal input/output
- Display: LCD screen

SOFTWARE

- Upgrade software through DMX signal or USB interface
- Silent fan, three working modes (silent/standard/high brightness)

X/Y-AXIS MOTION ANGLE

- X-axis: 540 ° 8-bit/16bit precision scanning
- Y-axis: 270 ° 8-bit/16bit precision scanning
- Reset function with automatic error correction
- Fixed lock: Y-axis lock

POWER

- Input voltage: AC 100-240V 50/60Hz
- Maximum power: 1050W (100V input)
- Power factor: 0.996
- Maximum current of the lamp: 10.5A (100V input)

SIZE AND WEIGHT

- Product size: 442 × 282 × 788mm
- N.W.: 37.5 kg
- Carton packaging (default): 660 × 560 × 740mm
G.W.: 46.6 kg
- EPP-Flycase Size(1 unit): 700 × 700 × 880mm
- G.W.:75.1 kg

OTHER

- Protection level: IP20
- Working environment: -10 °C~45°C
- Maximum surface temperature of lamp body:75°C
- Hook: Suitable for pipes with a diameter of 50-60 mm.

STANDARDS AND CERTIFICATION

- The product implementation standard: IEC 60598-1、IEC 60598-2-17
- Approved certifications: CE、RoHs
- The product complies with the following EU directives:
Low Voltage Directive 2014/35/EU . EMC Directive 2014/30/EU

illumination diagram

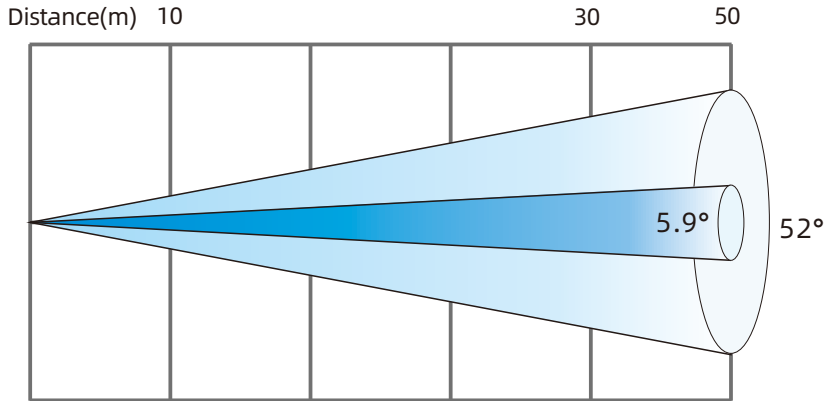

| | 10 | 20 | 30 | 40 | 50 |
|-------------|-------|-------|-------|-------|------|
| 5.9° Lux R | 720 | 320 | 180 | 80 | 30 |
| G | 2100 | 930 | 520 | 230 | 85 |
| B | 430 | 190 | 110 | 50 | 20 |
| A | 1580 | 700 | 400 | 180 | 60 |
| L | 8600 | 3800 | 2150 | 950 | 340 |
| RGBAL | 12500 | 5556 | 3125 | 1389 | 500 |
| Diameter(m) | 1.07 | 1.6 | 2.14 | 3.21 | 5.35 |
| 52° Lux R | 20 | 9 | 5 | 2 | 1 |
| G | 50 | 22 | 13 | 6 | 2 |
| B | 10 | 4 | 3 | 1 | 0 |
| A | 36 | 16 | 9 | 4 | 1 |
| L | 200 | 89 | 50 | 22 | 8 |
| RGBAL | 300 | 130 | 75 | 30 | 12 |
| Diameter(m) | 9.82 | 14.73 | 19.64 | 29.46 | 49.1 |

2.1.Attachment And Size

Attachment contents-Fig.1

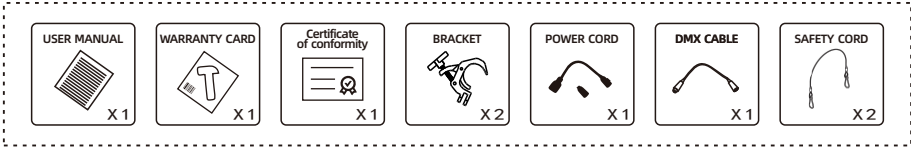

Size-Fig.2(Unit:mm)

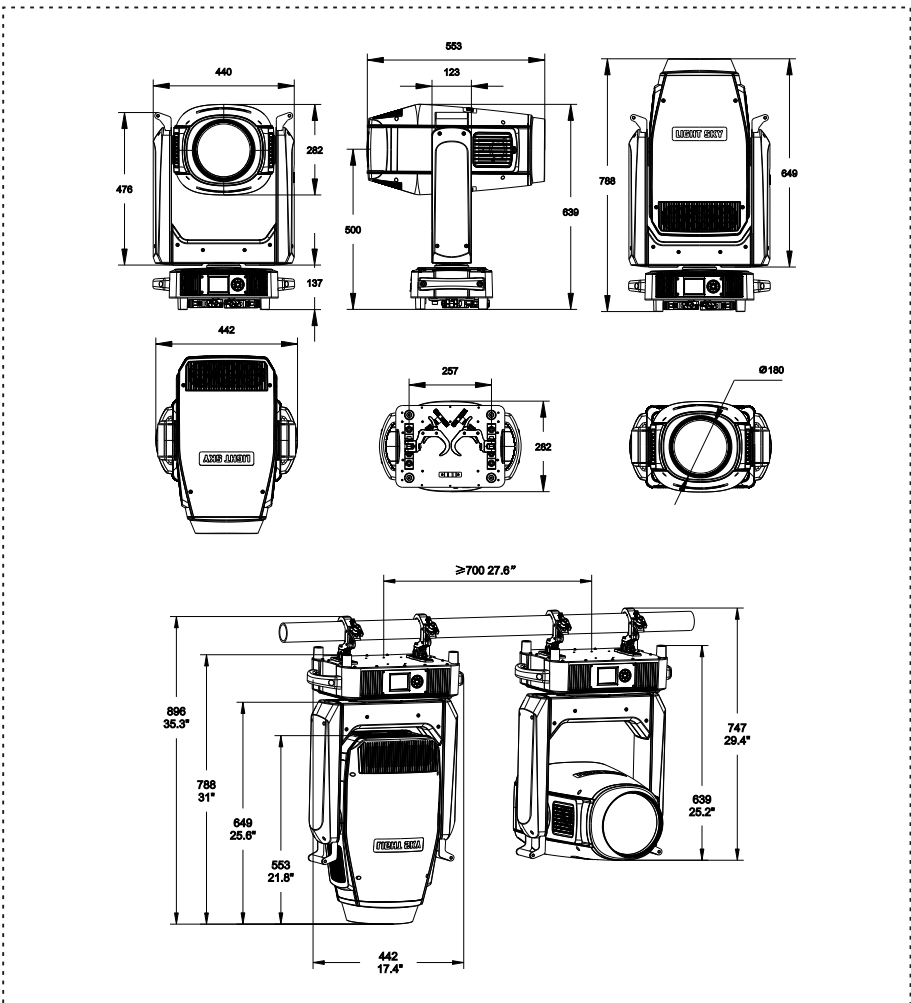

Tilt=0 DMX

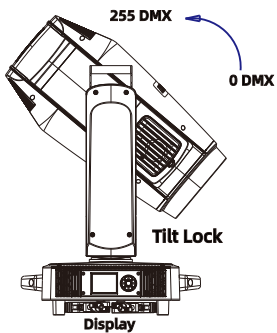

Tilt=128 DMX

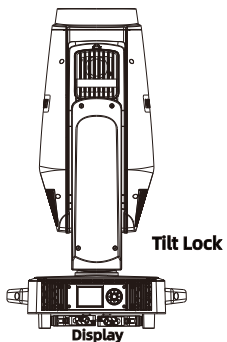

Tilt=255 DMX

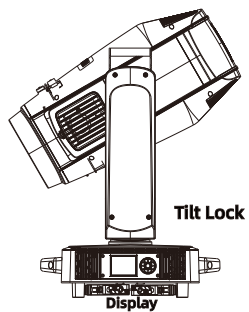

Pan=0 DMX

Power cord

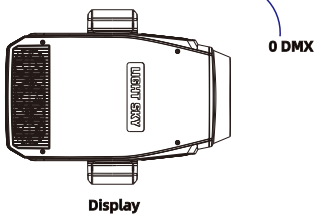

Pan=128 DMX

Power cord

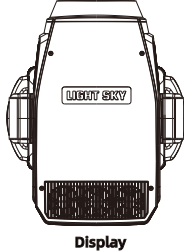

Pan=255 DMX

Power cord

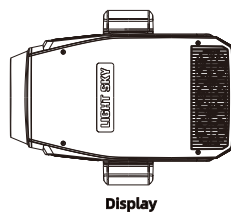

3.Prism/CMY/Effect/Pattern



8 Prism



CMY+CTO

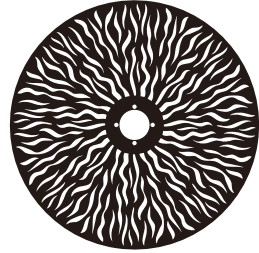

Effect wheel

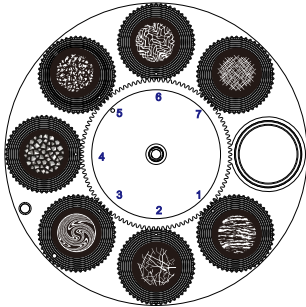

Rotating gobo wheel A



FG2430



FG2429



FG2428



FG2427



FG2426



FG2425



FG2424



21.5 mm
26.9 mm
Rotation Gobo Size

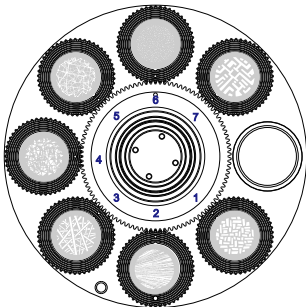

Rotating gobo wheel B



FG2437



FG2436



FG2435



FG2434



FG2433



FG2432



FG2431



21.5 mm
26.9 mm
Rotation Gobo Size

DANGER! Attention: When installing GOGO chips, it is necessary to strictly follow the order of the pictures and not change the original order and direction of the GOGO chips at will. Please disconnect the power supply when installing/replacing the rotating pattern piece!

3.1.Replacing Rotating Gobos

1.Use a screwdriver to unscrew the two screws at A to take out the pattern color module assembly;

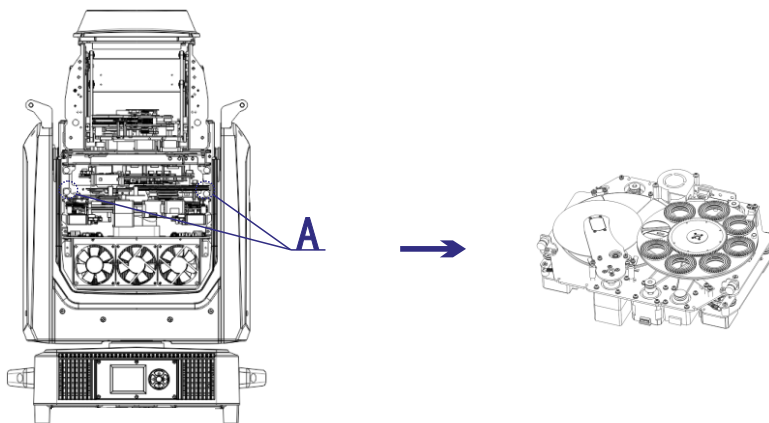

2. Reverse the assembly, and use a screwdriver to unscrew the four screws at B to separate the pattern color module from the CMY module;

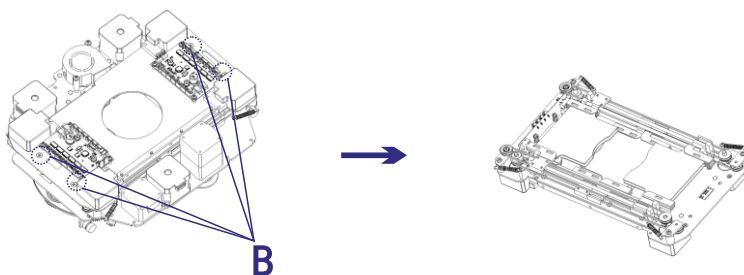

3. Use a screwdriver from the front of the pattern module to unscrew the two screws of the magnetic induction board at C, and remove the magnetic induction board; then half loosen the screws on the three motors at D, move the motor and take off the belt; turn the pattern module back Come here, unscrew the four screws at E with a screwdriver, and you can take out the rotating gobo and fixed gobo assembly (as shown in Figure F, the front is the rotating gobo, and the back is the fixed gobo).

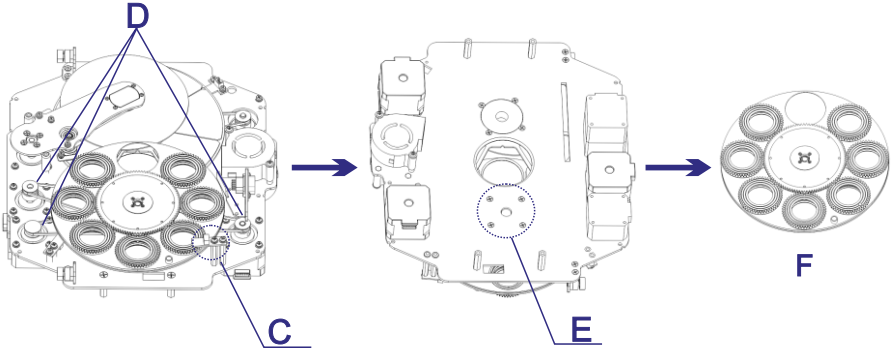

4. As shown in G, gently lift the gobo driven wheel from the edge upwards from the back of the gobo wheel and pull it out slowly to take out a single gobo;

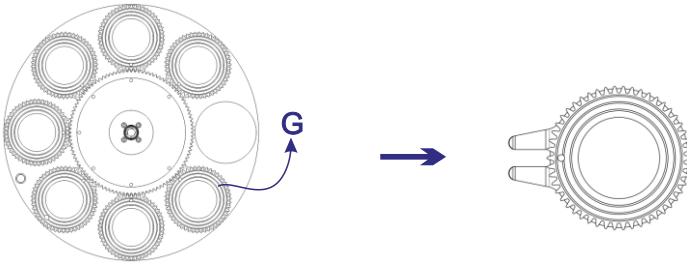

5. Take out the circlip at H with tweezers or other small objects that can be held (if the gobo is coated with glass glue for fixing, please use a professional cleaning agent to remove the glass glue and then take out the circlip to avoid damage to the gobo);

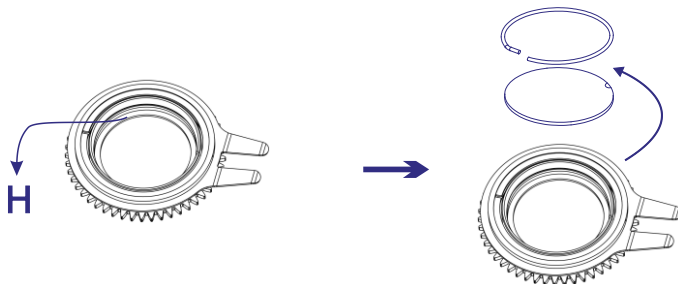

6. When assembling the gobo, avoid touching the gobo directly with your hands, and as shown in I, align the notched part of the gobo with the depression of the driven wheel assembly (the coating surface of the gobo should face the light source);

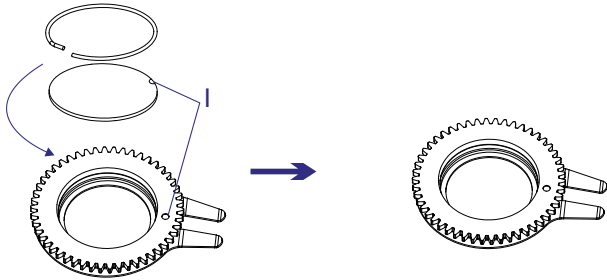

7. Insert the gobo driven wheel into the driving wheel assembly, as shown in J, the concave point of the gobo driven wheel must be positioned towards the center of the driving wheel;

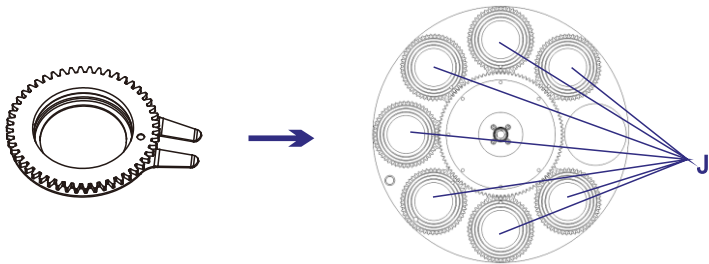

8. After installation, put the component back to the fixture.

4.Control Panel

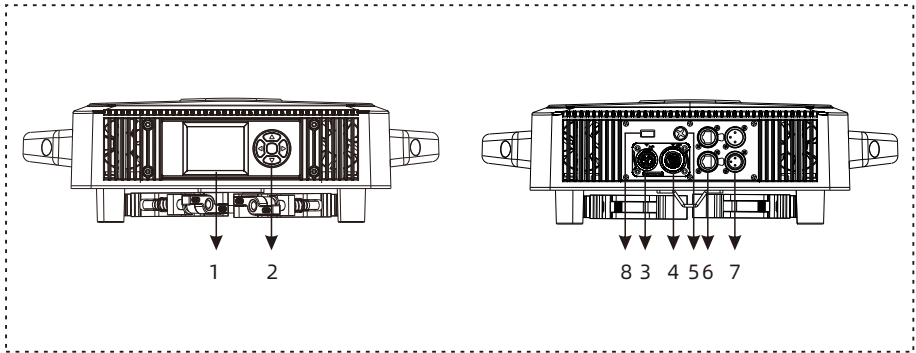

1.Display: To show the various menus and the selected function

2.Button:

| | |
|---|---------------------|
| ● | OK confirmation key |
| ▲ | UP |
| ▼ | DOWN |
| ◀ | To the left |
| ▶ | To the right |

3. Power input: Connect the power supply to provide power.

4. Power output: Connect the lamp power output adapter.

5.Fuse holder: Used for the bottom box battery pack power supply display board when not powered on.(Note: In the case of air transportation, the lighting fixtures will require disassembly of fuses for shipment, and they must be installed by themselves upon receipt.)

6.Art-net: The information of the lamp can be transmitted to the main controller through the network cable, and the lamp can be controlled through RJ45(optional).

7.DMX input/output: Used for DMX512 connection, use 3/5 core XLR signal cable to connect console and lamps,And input/output DMX signal.

8. USB port: used for updating software versions.

5.Connection and control

5.1.Power supply connection

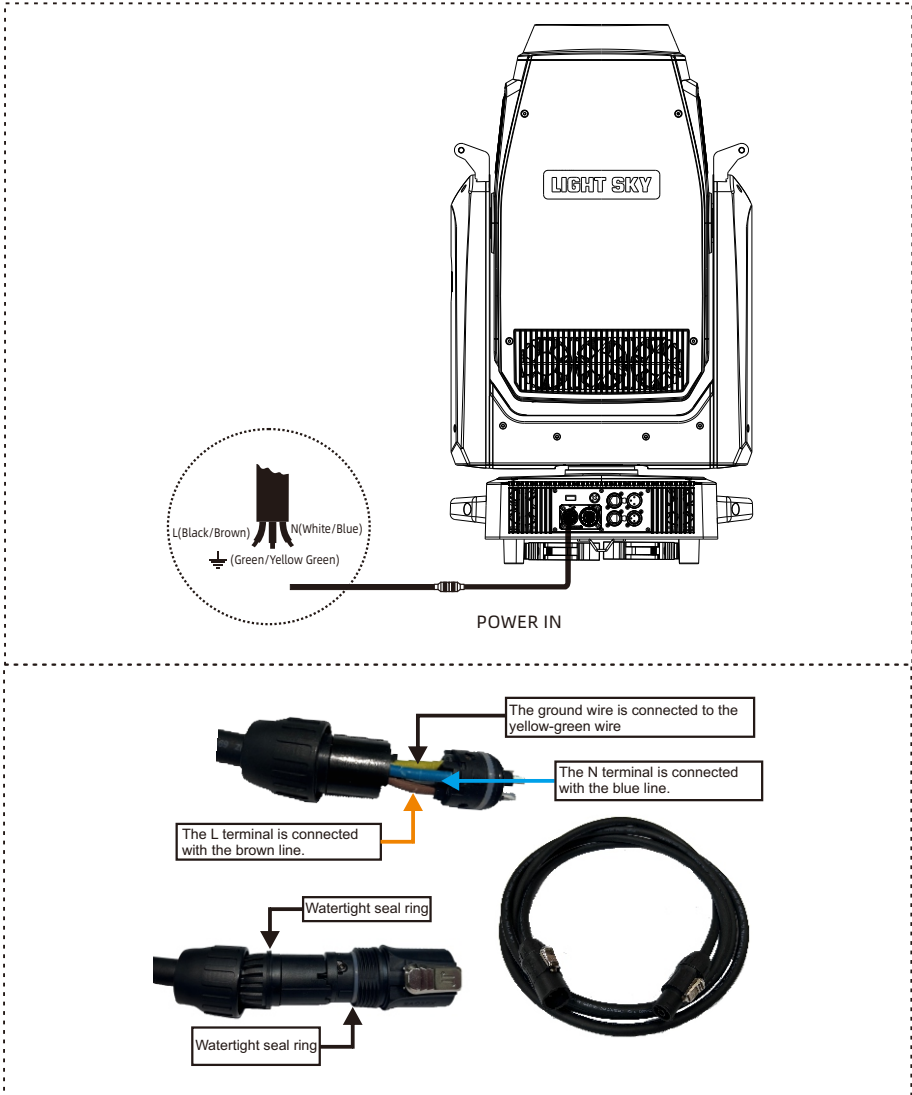

- The bus connecting the power supply must be installed by a qualified professional technician.
- After completing all the above operations and ensuring that it is installed, you can power on the lamp to operate.

5.2.DMX 512 Connection

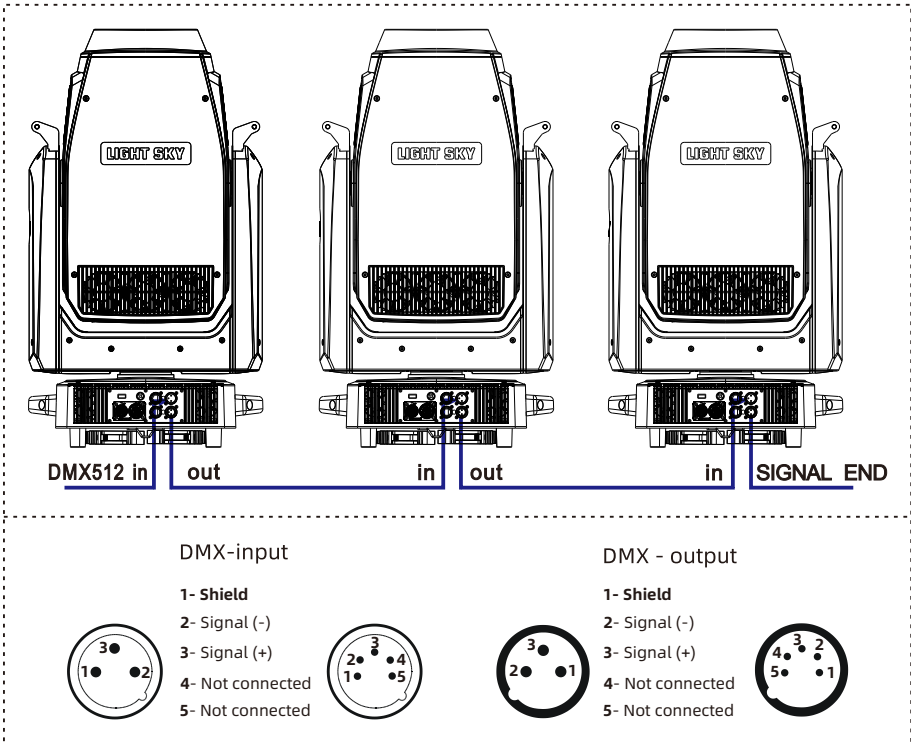

1. At last unit, the DMX cable has to be terminated with a terminator. Solder a 120 Ω 1/4W resistor between pin 2(DMX-) and pin 3(DMX+) into a 3-pin XLR-plug and plug it in the DMX-output of the last unit.
 2. Connect the unit together in a “daisy chain” by XLR plug cable from the output of the unit to the input of the next unit. The cable cannot be branched or split to a “Y” cable. DMX 512 is a very high-speed signal. Inadequate or damaged cables, soldered joints or corroded connectors can easily distort the signal and shut down the system.
 3. The DMX output and input connectors are pass-through to maintain the DMX circuit, when one of the units’ power is disconnected.
 4. Each lighting unit needs to have a DMX address to receive the data by the controller. The address number is between 1-512.
 5. The end of the DMX 512 system should be terminated to reduce signal errors.
 6. 3 pin XLR connectors are more popular than 5 pins XLR.
- 3 pin XLR: Pin 1: GND, Pin 2: Negative signal (-), Pin 3: Positive signal (+)
 5 pin XLR: Pin 1: GND, Pin 2: Negative signal (-), Pin 3: Positive signal (+), Pin4, Pin5 not used.

6.How To Set The Unit

6.1.Main Function

| Main menu | I menu | II menu | III menu | IV menu |
|--------------|---------------------|--------------------|------------|---------|
| DMX SETTING | Address | → 1-512 | | |
| | Channel mode | → Standard (60) | | |
| | | → Basic(35) | | |
| | | → Extended(64) | | |
| | Dmx state | → Compatible(49) | | |
| → Black | | | | |
| Input mode | → Hold | | | |
| | → DMX 512 | | | |
| Info | Fixture times | → Power on time | 0 - 99999H | |
| | | → LED on time | 0 - 99999H | |
| | | → All time | 0 - 99999H | |
| | Temperatures | → LED TEMP | XXXX°C | |
| | | → Drive TEMP | XXXX°C | |
| | RDM info | → UID:0x3888XXXXXX | | |
| | DMX live | → 1.Pan | 0 - 255 | |
| | | → 2.Pan fine | 0 - 255 | |
| | | → 3..... | 0 - 255 | |
| | Version info | → Display | VX.XXX | |
| | | → Pan/Tilt | VX.XXX | |
| | | → Gobo module | VX.XXX | |
| | | → Profile1 | VX.XXX | |
| | | → Profile2 | VX.XXX | |
| | | → Zoom module | VX.XXX | |
| Fan Info | | → LedFanDrv | VX.XXX | |
| | | → InFan | xxx V | |
| | | → OutFan | xxx V | |
| | | → GoboFan | xxx V | |
| | | → ProfileFan | xxx V | |
| | | → FocusFan | xxx V | |
| | | → InFan1 | OK/Error | |
| | | → InFan2 | OK/Error | |
| | | → InFan3 | OK/Error | |
| | | → OutFan1 | OK/Error | |
| | | → OutFan2 | OK/Error | |
| | | → OutFan3 | OK/Error | |
| | | → GoboFan | OK/Error | |
| | | → ProfileFan | OK/Error | |
| | | → FocusFan1 | OK/Error | |
| → FocusFan2 | OK/Error | | | |
| Person | Tilt /Pan | → PT swap | OFF | |
| | | → ON | | |
| | | → Pan invert | OFF | |
| | | → ON | | |
| | | → Tilt invert | OFF | |
| | | → ON | | |
| | | → PT Encoder | OFF | |
| | | → ON | | |
| | | → PT Mode | Speed | |
| | | → Time | | |
| | → PT move black | OFF | | |
| | → ON | | | |
| | | Off | | |
| | → PT Follow Spot | Soft | | |
| | | Medium | | |
| | Hard | | | |
| → PT Parking | OFF | | | |
| | ON | | | |
| Noise mode | → Silent | | | |
| | → Standard | | | |
| | → High Output | | | |
| Display | → Language | → English | | |
| | | → Chinese | | |
| | → Backlight time | → Always | | |
| | → Intensity | → Auto (305) | | |
| Ethernet Set | | → Rotation | → 0 - 100 | |
| | | | → Normal | |
| | | → Rotate 180 | | |
| | → IP Address | xxx.xxx.xxx.xxx | | |
| | → Mask Address | xxx.xxx.xxx.xxx | | |
| | → Universe Address | 0-32767 | | |
| | → SACN Universe Add | 1-63999 | | |

| Main menu | I menu | II menu | III menu | IV menu | |
|-------------|---------------|-------------------|---|---------------------------------|--|
| | | DHCP | OFF ON | | |
| | | | Ethernet To DMX | OFF ON | |
| | | Dimmer Curve | Linear Square(Default) I-Square SCurve | | |
| | | Led Preq Set | 4000 Hz 8000 Hz 16000 Hz 25000 Hz | | |
| | | Zoom Invert Set | OFF ON | | |
| | | Color Mixing Mode | CMY RGB | | |
| | | Tungsten Effect | Off 750W/80V 1000W/240V 1200W/240V 2000W/230V 2500W/230V | | |
| | | Light Out Stab. | OFF ON | | |
| | | FX Auto Focus | OFF ON | | |
| | | ICC | OFF ON | | |
| | Manual | Manual Control | 1.Pan → 2.Pan fine 3..... | 0 - 255 → 0 - 255 0 - 255 | |
| | | Reset | Total reset Pan/Tilt reset Gobo reset Profile reset Focus reset Effect reset | | |
| | Test | Test all | Testing | | |
| | | Test pan/tilt | Testing | | |
| | | Test effects | Testing | | |
| | Fixture state | Memory IC | OK/Reset/Error | | |
| | | Angle Sensor | OK/Reset/Error | | |
| | | Pan Encoder | OK/Reset/Error | | |
| | | Tilt Encoder | OK/Reset/Error | | |
| | | Pan | OK/Reset/Error | | |
| | | Tilt | OK/Reset/Error | | |
| | | Gobo1 | OK/Reset/Error | | |
| | | → Gobo1 Rot. | OK/Reset/Error | | |
| | | Gobo2 | OK/Reset/Error | | |
| | | Gobo2 Rot. | OK/Reset/Error | | |
| | | Fram Rot. | OK/Reset/Error | | |
| | | Zoom | OK/Reset/Error | | |
| | | Focus | OK/Reset/Error | | |
| | | Prism | OK/Reset/Error | | |
| | | Prism Rot. | OK/Reset/Error | | |
| | Adjust | Pan | 0 - 255 | | |
| | | Tilt | 0 - 255 | | |
| | | Red | 0 - 255 | | |
| | | Green | 0 - 255 | | |
| | | Blue | 0 - 255 | | |
| | | Amber | 0 - 255 | | |
| | | LightGreen | 0 - 255 | | |
| | | Gobo1 | 0 - 255 | | |
| | | Gobo1 Rot. | 0 - 255 | | |
| | | Gobo2 | 0 - 255 | | |
| | | Gobo2 Rot. | 0 - 255 | | |
| | | Blade 1A | 0 - 255 | | |
| Blade 1B | 0 - 255 | | | | |
| Blade 2A | 0 - 255 | | | | |
| Blade 2B | 0 - 255 | | | | |
| Blade 3A | 0 - 255 | | | | |
| → Blade 3B | → 0 - 255 | | | | |
| Blade 4A | 0 - 255 | | | | |
| Blade 4B | 0 - 255 | | | | |
| FramingRot. | 0 - 255 | | | | |
| Prism | 0 - 255 | | | | |
| Prism Rot. | 0 - 255 | | | | |
| Effect | 0 - 255 | | | | |

| Main menu | I menu | II menu | III menu | IV menu | |
|---------------------|-------------------|---------------|-----------------------|-------------|--|
| | | Light Frost | 0 - 255 | | |
| | | Medium Frost | 0 - 255 | | |
| | | Iris | 0 - 255 | | |
| | | Zoom | 0 - 255 | | |
| | | Focus | 0 - 255 | | |
| | | Dimmer | 0 - 255 | | |
| | | FosForGo1 | 0 - 255 | | |
| | | FosForGo2 | 0 - 255 | | |
| | | FosForIris | 0 - 255 | | |
| | | FosForEffect | 0 - 255 | | |
| Service | Color Calibration | Filter4 | Red(xxx) | 0-255 | |
| | | | Green(xxx) | 0-255 | |
| | | | Blue(xxx) | 0-255 | |
| | | | Amber(xxx) | 0-255 | |
| | | | LightGreen(xxx) | 0-255 | |
| | | Filter10 | Red(xxx) | 0-255 | |
| | | | Green(xxx) | 0-255 | |
| | | | Blue(xxx) | 0-255 | |
| | | | Amber(xxx) | 0-255 | |
| | | Filter19 | Red(xxx) | 0-255 | |
| | | | Green(xxx) | 0-255 | |
| | | | Blue(xxx) | 0-255 | |
| | | Filter778 | Amber(xxx) | 0-255 | |
| | | | LightGreen(xxx) | 0-255 | |
| | | | Red(xxx) | 0-255 | |
| | | | Green(xxx) | 0-255 | |
| | | | Blue(xxx) | 0-255 | |
| | | Filter793 | Amber(xxx) | 0-255 | |
| | | | LightGreen(xxx) | 0-255 | |
| | | | Red(xxx) | 0-255 | |
| Green(xxx) | 0-255 | | | | |
| Factory | Factory | Factory Reset | YES /NO | | |
| | | Reset timers | Reset power on timers | YES/NO | |
| | | | Reset led timers | YES | |
| | | | Reset all timers | YES | |
| | | Update | Simple update | Display | |
| | | | | Pan/Tilt | |
| | | | | Gobo module | |
| | | | Framing module1 | | |
| | | | Framing module2 | | |
| | | | Zoom module | | |
| | | Whole update | LEDQD | | |
| | | | ALL | | |
| | | | ALL | | |
| | | Power select | | | |
| | | Logo select | | | |
| Fixture Type | | | | | |
| Framing Adjust Mode | OFF | | | | |
| | ON | | | | |
| ICC Test | OFF | | | | |
| | ON | | | | |

6.2.Channel Setting

Press the OK button to confirm, use the up/down buttons to select the channel mode: mode 1 (60CH), mode 2 (35CH), mode 3 (64CH), mode 4 (49CH),press the OK button to save. Press the left/right button to return to the previous menu.

6.3.Address Setting

When using a universal DMX controller to control the fixture, you need to set the starting address (1-512) for the fixture so that the machine can receive the DMX signal.Select the DMX address, press the OK button to confirm, the current DMX address will be shown on the display. Use the left/right buttons to select 001~512 address, press the OK button to save. Press the left/right button to return to the previous menu.

Please refer to the following diagram to address your DMX512 channel for the first 4 units.

| Channel mode | Unit 1 Address | Unit 2 Address | Unit 3 Address | Unit 4 Address |
|--------------|-------------------|-------------------|-------------------|-------------------|
| 60 Channel | 1 | 61 | 121 | 181 |
| 35 Channel | 1 | 36 | 71 | 106 |
| 64 Channel | 1 | 65 | 129 | 193 |
| 49 Channel | 1 | 50 | 99 | 148 |

6.4.DMX 512 Configuration

| 60 Channel | 35 Channel | 64 Channel | 49 Channel | DMX | Function | Note |
|------------|------------|------------|------------|---|--|--------------------------------|
| 1 | 1 | 1 | 1 | 0-255 | Pan Pan movement/positioning | Angle: 0-540° Maximum:3.655 |
| 2 | 2 | 2 | 2 | 0-255 | Pan fine Fine pan positioning | |
| 3 | 3 | 3 | 3 | 0-255 | TILT Tilt movement/positioning | Angle: 0-270° Maximum:2.285 |
| 4 | 4 | 4 | 4 | 0-255 | TILT fine Fine tilt movement/positioning | |
| 5 | 5 | 5 | 5 | 0 1 2-255 2-255 | PAN/TILT Speed, Pan/Tilt time Standard mode (0=default) Max. Speed Mode Pan/Tilt speed mode Speed from max. to min. Pan/Tilt time mode Time from 0.2 sec. to 25.5 sec. | |
| 6 | 6 | 6 | 6 | 0-9 10-14 15-19 20-24 25-29 30-34 35-39 40-44 45-49 50-54 55-59 60-64 65-69 70-74 75-79 80-84 85-89 90-94 95-99 100-104 105-119 120-124 125-129 130-139 140-149 150-159 160-169 170-179 180-189 190-199 200-209 210-211 212-213 214-215 216-218 219-220 221-222 223-224 225-229 230-234 235-239 240 241-255 | Functions To activate following functions, stop in DMX value for at least 3s Reserved (0=default) DMX input: DMX DMX input: Art-Net Display Back light is on Display Back light is auto(Default) Zoom Invert Zoom Forward(Default) Pan/Tilt mode: Speed(Default) Pan/Tilt mode: Time Blackout while pan/tilt moving: On Blackout while pan/tilt moving: Off (Default) Reserved Reserved Fan mode: Silent Fan mode: Standard (Default) Fan mode: High Output DMX state: Black (Default) DMX state: Hold ICC off ICC on (Default) Reserved Parking position on Parking position off (Default) Fixture reset(except pan/tilt) Pan/Tilt reset Reserved Gobo wheels/effect wheel reset Reserved Zoom/focus/frosts/prisms reset Iris / framing shutters reset Total fixture reset Green correction calibration FX Auto Focus on FX Auto Focus off Reserved The following three commands define transition from gobo rotation to gobo indexing: Maximum speed and shortcut (Use in future,now no function) Follow speed and direction (Use in future,now no function) Maximum speed and follow direction (Use in future,now no function) The following RoboSpot related commands are only applicable when the RoboSpot is connected:(Use in future,now no function) RoboSpot enabled(Use in future,now no function) RoboSpot disabled - except handle faders and pan/tilt(Use in future,now no function) RoboSpot fully disabled (Use in future,now no function) Disabled "Quiet mode" Quiet mode - fan noise control from min. to max. | |
| 7 | / | 7 | 7 | 0-4 5-9 10-14 15-19 20-24 25-255 | LED frequency selection Factory display menu setting: 8000Hz Select PWM output frequency of LEDs. Selected PWM frequency can be fine adjusted in 127 steps up/down around selected PWM frequency on the channel below. Corresponding menu item (Frequency Setup) is temporarily overridden. PWM frequency from Display menu (fixture utilizes PWM frequency set in the display menu item Frequency Setup). 4000 Hz 8000 Hz (10=default) 16000 Hz 25000 Hz Reserved (fixture utilizes PWM frequency set in the display menu item | |

| 60 Channel | 35 Channel | 64 Channel | 49 Channel | DMX | Function | Note |
|------------|------------|------------|------------|-----|--|------|
| | | | | | LED frequency fine adjusting Factory display menu setting: 8000Hz Select desired PWM output frequency of LEDs on the channel above. | |
| | | | | 0-1 | Selected LED Frequency | |
| | | | | 2 | LED Frequency (step -126) | |
| | | | | 3 | LED Frequency (step -125) | |
| | | | | 4 | LED Frequency (step -124) | |
| | | | | 5 | LED Frequency (step -123) | |
| | | | | 6 | LED Frequency (step -122) | |
| | | | | 7 | LED Frequency (step -121) | |
| | | | | 8 | LED Frequency (step -120) | |
| | | | | 9 | LED Frequency (step -119) | |
| | | | | 10 | LED Frequency (step -118) | |
| | | | | 11 | LED Frequency (step -117) | |
| | | | | 12 | LED Frequency (step -116) | |
| | | | | 13 | LED Frequency (step -115) | |
| | | | | 14 | LED Frequency (step -114) | |
| | | | | 15 | LED Frequency (step -113) | |
| | | | | 16 | LED Frequency (step -112) | |
| | | | | 17 | LED Frequency (step -111) | |
| | | | | 18 | LED Frequency (step -110) | |
| | | | | 19 | LED Frequency (step -109) | |
| | | | | 20 | LED Frequency (step -108) | |
| | | | | 21 | LED Frequency (step -107) | |
| | | | | 22 | LED Frequency (step -106) | |
| | | | | 23 | LED Frequency (step -105) | |
| | | | | 24 | LED Frequency (step -104) | |
| | | | | 25 | LED Frequency (step -103) | |
| | | | | 26 | LED Frequency (step -102) | |
| | | | | 27 | LED Frequency (step -101) | |
| | | | | 28 | LED Frequency (step -100) | |
| | | | | 29 | LED Frequency (step -99) | |
| | | | | 30 | LED Frequency (step -98) | |
| | | | | 31 | LED Frequency (step -97) | |
| | | | | 32 | LED Frequency (step -96) | |
| | | | | 33 | LED Frequency (step -95) | |
| | | | | 34 | LED Frequency (step -94) | |
| | | | | 35 | LED Frequency (step -93) | |
| | | | | 36 | LED Frequency (step -92) | |
| | | | | 37 | LED Frequency (step -91) | |
| | | | | 38 | LED Frequency (step -90) | |
| | | | | 39 | LED Frequency (step -89) | |
| | | | | 40 | LED Frequency (step -88) | |
| | | | | 41 | LED Frequency (step -87) | |
| | | | | 42 | LED Frequency (step -86) | |
| | | | | 43 | LED Frequency (step -85) | |
| | | | | 44 | LED Frequency (step -84) | |
| | | | | 45 | LED Frequency (step -83) | |
| | | | | 46 | LED Frequency (step -82) | |
| | | | | 47 | LED Frequency (step -81) | |
| | | | | 48 | LED Frequency (step -80) | |
| | | | | 49 | LED Frequency (step -79) | |
| | | | | 50 | LED Frequency (step -78) | |
| | | | | 51 | LED Frequency (step -77) | |
| | | | | 52 | LED Frequency (step -76) | |
| | | | | 53 | LED Frequency (step -75) | |
| | | | | 54 | LED Frequency (step -74) | |
| | | | | 55 | LED Frequency (step -73) | |
| | | | | 56 | LED Frequency (step -72) | |
| | | | | 57 | LED Frequency (step -71) | |
| | | | | 58 | LED Frequency (step -70) | |
| | | | | 59 | LED Frequency (step -69) | |
| | | | | 60 | LED Frequency (step -68) | |
| | | | | 61 | LED Frequency (step -67) | |
| | | | | 62 | LED Frequency (step -66) | |
| | | | | 63 | LED Frequency (step -65) | |
| | | | | 64 | LED Frequency (step -64) | |
| | | | | 65 | LED Frequency (step -63) | |
| | | | | 66 | LED Frequency (step -62) | |
| | | | | 67 | LED Frequency (step -61) | |
| | | | | 68 | LED Frequency (step -60) | |
| | | | | 69 | LED Frequency (step -59) | |
| | | | | 70 | LED Frequency (step -58) | |
| | | | | 71 | LED Frequency (step -57) | |
| | | | | 72 | LED Frequency (step -56) | |
| | | | | 73 | LED Frequency (step -55) | |
| | | | | 74 | LED Frequency (step -54) | |
| | | | | 75 | LED Frequency (step -53) | |

| 60 Channel | 35 Channel | 64 Channel | 49 Channel | DMX | Function | Note |
|------------|------------|------------|------------|-----|--------------------------------------|------|
| | | | | 76 | LED Frequency (step -52) | |
| | | | | 77 | LED Frequency (step -51) | |
| | | | | 78 | LED Frequency (step -50) | |
| | | | | 79 | LED Frequency (step -49) | |
| | | | | 80 | LED Frequency (step -48) | |
| | | | | 81 | LED Frequency (step -47) | |
| | | | | 82 | LED Frequency (step -46) | |
| | | | | 83 | LED Frequency (step -45) | |
| | | | | 84 | LED Frequency (step -44) | |
| | | | | 85 | LED Frequency (step -43) | |
| | | | | 86 | LED Frequency (step -42) | |
| | | | | 87 | LED Frequency (step -41) | |
| | | | | 88 | LED Frequency (step -40) | |
| | | | | 89 | LED Frequency (step -39) | |
| | | | | 90 | LED Frequency (step -38) | |
| | | | | 91 | LED Frequency (step -37) | |
| | | | | 92 | LED Frequency (step -36) | |
| | | | | 93 | LED Frequency (step -35) | |
| | | | | 94 | LED Frequency (step -34) | |
| | | | | 95 | LED Frequency (step -33) | |
| | | | | 96 | LED Frequency (step -32) | |
| | | | | 97 | LED Frequency (step -31) | |
| | | | | 98 | LED Frequency (step -30) | |
| | | | | 99 | LED Frequency (step -29) | |
| | | | | 100 | LED Frequency (step -28) | |
| | | | | 101 | LED Frequency (step -27) | |
| | | | | 102 | LED Frequency (step -26) | |
| | | | | 103 | LED Frequency (step -25) | |
| | | | | 104 | LED Frequency (step -24) | |
| | | | | 105 | LED Frequency (step -23) | |
| | | | | 106 | LED Frequency (step -22) | |
| | | | | 107 | LED Frequency (step -21) | |
| | | | | 108 | LED Frequency (step -20) | |
| | | | | 109 | LED Frequency (step -19) | |
| | | | | 110 | LED Frequency (step -18) | |
| | | | | 111 | LED Frequency (step -17) | |
| | | | | 112 | LED Frequency (step -16) | |
| | | | | 113 | LED Frequency (step -15) | |
| | | | | 114 | LED Frequency (step -14) | |
| | | | | 115 | LED Frequency (step -13) | |
| | | | | 116 | LED Frequency (step -12) | |
| | | | | 117 | LED Frequency (step -11) | |
| | | | | 118 | LED Frequency (step -10) | |
| | | | | 119 | LED Frequency (step -9) | |
| | | | | 120 | LED Frequency (step -8) | |
| | | | | 121 | LED Frequency (step -7) | |
| | | | | 122 | LED Frequency (step -6) | |
| | | | | 123 | LED Frequency (step -5) | |
| | | | | 124 | LED Frequency (step -4) | |
| | | | | 125 | LED Frequency (step -3) | |
| 8 | / | 8 | 8 | 126 | LED Frequency (step -2) | |
| | | | | 127 | LED Frequency (step -1) | |
| | | | | 128 | Selected LED Frequency (128=default) | |
| | | | | 129 | LED Frequency (step +1) | |
| | | | | 130 | LED Frequency (step +2) | |
| | | | | 131 | LED Frequency (step +3) | |
| | | | | 132 | LED Frequency (step +4) | |
| | | | | 133 | LED Frequency (step +5) | |
| | | | | 134 | LED Frequency (step +6) | |
| | | | | 135 | LED Frequency (step +7) | |
| | | | | 136 | LED Frequency (step +8) | |
| | | | | 137 | LED Frequency (step +9) | |
| | | | | 138 | LED Frequency (step +10) | |
| | | | | 139 | LED Frequency (step +11) | |
| | | | | 140 | LED Frequency (step +12) | |
| | | | | 141 | LED Frequency (step +13) | |
| | | | | 142 | LED Frequency (step +14) | |
| | | | | 143 | LED Frequency (step +15) | |
| | | | | 144 | LED Frequency (step +16) | |
| | | | | 145 | LED Frequency (step +17) | |
| | | | | 146 | LED Frequency (step +18) | |
| | | | | 147 | LED Frequency (step +19) | |
| | | | | 148 | LED Frequency (step +20) | |
| | | | | 149 | LED Frequency (step +21) | |
| | | | | 150 | LED Frequency (step +22) | |
| | | | | 151 | LED Frequency (step +23) | |
| | | | | 152 | LED Frequency (step +24) | |
| | | | | 153 | LED Frequency (step +25) | |
| | | | | 154 | LED Frequency (step +26) | |

| 60 Channel | 35 Channel | 64 Channel | 49 Channel | DMX | Function | Note |
|------------|------------|------------|------------|-----|---------------------------|------|
| | | | | 155 | LED Frequency (step +27) | |
| | | | | 156 | LED Frequency (step +28) | |
| | | | | 157 | LED Frequency (step +29) | |
| | | | | 158 | LED Frequency (step +30) | |
| | | | | 159 | LED Frequency (step +31) | |
| | | | | 160 | LED Frequency (step +32) | |
| | | | | 161 | LED Frequency (step +33) | |
| | | | | 162 | LED Frequency (step +34) | |
| | | | | 163 | LED Frequency (step +35) | |
| | | | | 164 | LED Frequency (step +36) | |
| | | | | 165 | LED Frequency (step +37) | |
| | | | | 166 | LED Frequency (step +38) | |
| | | | | 167 | LED Frequency (step +39) | |
| | | | | 168 | LED Frequency (step +40) | |
| | | | | 169 | LED Frequency (step +41) | |
| | | | | 170 | LED Frequency (step +42) | |
| | | | | 171 | LED Frequency (step +43) | |
| | | | | 172 | LED Frequency (step +44) | |
| | | | | 173 | LED Frequency (step +45) | |
| | | | | 174 | LED Frequency (step +46) | |
| | | | | 175 | LED Frequency (step +47) | |
| | | | | 176 | LED Frequency (step +48) | |
| | | | | 177 | LED Frequency (step +49) | |
| | | | | 178 | LED Frequency (step +50) | |
| | | | | 179 | LED Frequency (step +51) | |
| | | | | 180 | LED Frequency (step +52) | |
| | | | | 181 | LED Frequency (step +53) | |
| | | | | 182 | LED Frequency (step +54) | |
| | | | | 183 | LED Frequency (step +55) | |
| | | | | 184 | LED Frequency (step +56) | |
| | | | | 185 | LED Frequency (step +57) | |
| | | | | 186 | LED Frequency (step +58) | |
| | | | | 187 | LED Frequency (step +59) | |
| | | | | 188 | LED Frequency (step +60) | |
| | | | | 189 | LED Frequency (step +61) | |
| | | | | 190 | LED Frequency (step +62) | |
| | | | | 191 | LED Frequency (step +63) | |
| | | | | 192 | LED Frequency (step +64) | |
| | | | | 193 | LED Frequency (step +65) | |
| | | | | 194 | LED Frequency (step +66) | |
| | | | | 195 | LED Frequency (step +67) | |
| | | | | 196 | LED Frequency (step +68) | |
| | | | | 197 | LED Frequency (step +69) | |
| | | | | 198 | LED Frequency (step +70) | |
| | | | | 199 | LED Frequency (step +71) | |
| | | | | 200 | LED Frequency (step +72) | |
| | | | | 201 | LED Frequency (step +73) | |
| | | | | 202 | LED Frequency (step +74) | |
| | | | | 203 | LED Frequency (step +75) | |
| | | | | 204 | LED Frequency (step +76) | |
| | | | | 205 | LED Frequency (step +77) | |
| | | | | 206 | LED Frequency (step +78) | |
| | | | | 207 | LED Frequency (step +79) | |
| | | | | 208 | LED Frequency (step +80) | |
| | | | | 209 | LED Frequency (step +81) | |
| | | | | 210 | LED Frequency (step +82) | |
| | | | | 211 | LED Frequency (step +83) | |
| | | | | 212 | LED Frequency (step +84) | |
| | | | | 213 | LED Frequency (step +85) | |
| | | | | 214 | LED Frequency (step +86) | |
| | | | | 215 | LED Frequency (step +87) | |
| | | | | 216 | LED Frequency (step +88) | |
| | | | | 217 | LED Frequency (step +89) | |
| | | | | 218 | LED Frequency (step +90) | |
| | | | | 219 | LED Frequency (step +91) | |
| | | | | 220 | LED Frequency (step +92) | |
| | | | | 221 | LED Frequency (step +93) | |
| | | | | 222 | LED Frequency (step +94) | |
| | | | | 223 | LED Frequency (step +95) | |
| | | | | 224 | LED Frequency (step +96) | |
| | | | | 225 | LED Frequency (step +97) | |
| | | | | 226 | LED Frequency (step +98) | |
| | | | | 227 | LED Frequency (step +99) | |
| | | | | 228 | LED Frequency (step +100) | |
| | | | | 229 | LED Frequency (step +101) | |
| | | | | 230 | LED Frequency (step +102) | |
| | | | | 231 | LED Frequency (step +103) | |
| | | | | 232 | LED Frequency (step +104) | |
| | | | | 233 | LED Frequency (step +105) | |

| 60 Channel | 35 Channel | 64 Channel | 49 Channel | DMX | Function | Note |
|------------|------------|------------|------------|---------|--|------|
| | | | | 234 | LED Frequency (step +106) | |
| | | | | 235 | LED Frequency (step +107) | |
| | | | | 236 | LED Frequency (step +108) | |
| | | | | 237 | LED Frequency (step +109) | |
| | | | | 238 | LED Frequency (step +110) | |
| | | | | 239 | LED Frequency (step +111) | |
| | | | | 240 | LED Frequency (step +112) | |
| | | | | 241 | LED Frequency (step +113) | |
| | | | | 242 | LED Frequency (step +114) | |
| | | | | 243 | LED Frequency (step +115) | |
| | | | | 244 | LED Frequency (step +116) | |
| | | | | 245 | LED Frequency (step +117) | |
| | | | | 246 | LED Frequency (step +118) | |
| | | | | 247 | LED Frequency (step +119) | |
| | | | | 248 | LED Frequency (step +120) | |
| | | | | 249 | LED Frequency (step +121) | |
| | | | | 250 | LED Frequency (step +122) | |
| | | | | 251 | LED Frequency (step +123) | |
| | | | | 252 | LED Frequency (step +124) | |
| | | | | 253 | LED Frequency (step +125) | |
| | | | | 254 | LED Frequency (step +126) | |
| | | | | 255 | Selected LED Frequency | |
| | | | | | Colour functions | |
| | | | | | Factory display menu setting: Colour mixing mode-CMY, Dimmer Curve-Square Law, Tungsten effect simulation -Off, Chromatic white-Off, Light output stability -Off, Uniformity -Off | |
| | | | | 0 | No function (0=default) | |
| | | | | | To activate following functions, stop in DMX value for at least 3 seconds. Corresponding menu items are temporarily overridden | |
| | | | | 1-39 | Reserved | |
| | | | | 40-44 | Colour mixing mode: CMY (DMX Standard, Basic and Compatible Mode only) | |
| | | | | 45-49 | Colour mixing mode: RGB (DMX Standard, Basic and Compatible Mode), RGBAL (DMX Extended Mode only) | |
| | | | | 50-54 | Dimmer curve: Square law | |
| | | | | 55-59 | Dimmer curve: Linear | |
| | | | | 60-64 | Dimmer curve: I-Square law | |
| | | | | 65-69 | Dimmer curve: S Curve | |
| | | | | 70-79 | Raw DMX | |
| | | | | | Tungsten effect simulation for whites 2700K-4200K only: | |
| | | | | 80-84 | Tungsten effect simulation (750W/80V): On | |
| | | | | 85-89 | Tungsten effect simulation (1000W/240V): On | |
| | | | | 90-94 | Tungsten effect simulation (1200W/240V): On | |
| | | | | 95-99 | Tungsten effect simulation (2000W/230V): On | |
| | | | | 100-104 | Tungsten effect simulation (2500W/230V): On | |
| | | | | 105-109 | Tungsten effect simulation: Off | |
| | | | | 110-114 | Reserved | |
| | | | | 115-119 | Chromatic white: On (Use in future, now no function) | |
| | | | | 120-124 | Chromatic white: Off (Use in future, now no function) | |
| | | | | 125-129 | Light output stability On | |
| | | | | 130-134 | Light output stability Off | |
| | | | | 135-139 | Uniformity On (Use in future, now no function) | |
| | | | | 140-144 | Uniformity Off (Use in future, now no function) | |
| | | | | 145-149 | Reserved | |
| | | | | 150-154 | Reserved | |
| | | | | 155-159 | Reserved | |
| | | | | 160-164 | Reserved | |
| | | | | 165-169 | Reserved | |
| | | | | 170-174 | Reserved | |
| | | | | 175-179 | Reserved | |
| | | | | 180-184 | Reserved | |
| | | | | 185-189 | Reserved | |
| | | | | 190-194 | Reserved | |
| | | | | 195-199 | Reserved | |
| | | | | 200-255 | Reserved | |
| | | | | | CRI selection | |
| | | | | 0-255 | CRI selection from Standard(CRI90+/R9:95+) to High light (CRI90+/R9:80) (0=default) | |
| | | | | | Virtual Colour wheel (Use in Standard Mode 60CH and Extended Mode 64CH) | |
| | | | | 0 | No function | |
| | | | | 1-2 | Filter 4 (Medium Bastard Amber) | |
| | | | | 3-4 | Filter 10 (Medium Yellow) | |
| | | | | 5-6 | Filter 19 (Fire) | |
| | | | | 7-8 | Filter 26 (Bright Red) | |
| | | | | 9-10 | Filter 58 (Lavender) | |
| 9 | 7 | 9 | 9 | | | |
| 10 | 8 | 10 | 10 | | | |

| 60 Channel | 35 Channel | 64 Channel | 49 Channel | DMX | Function | Note |
|------------|------------|------------|------------|---------|--|------|
| | | | | 11-12 | Filter 68 (Sky Blue) | |
| | | | | 13-14 | Filter 71 (Tokyo Blue) | |
| | | | | 15-16 | Filter 79 (Just Blue) | |
| | | | | 17-18 | Filter 88 (Lime Green) | |
| | | | | 19-20 | Filter 90 (Dark Yellow Green) | |
| | | | | 21-22 | Filter 100 (Spring Yellow) | |
| | | | | 23-24 | Filter 101 (Yellow) | |
| | | | | 25-26 | Filter 102 (Light Amber) | |
| | | | | 27-28 | Filter 103 (Straw) | |
| | | | | 29-30 | Filter 104 (Deep Amber) | |
| | | | | 31-32 | Filter 105 (Orange) | |
| | | | | 33-34 | Filter 106 (Primary Red) | |
| | | | | 35-36 | Filter 111 (Dark Pink) | |
| | | | | 37-38 | Filter 115 (Peacock Blue) | |
| | | | | 39-40 | Filter 116 (Medium Blue-Green) | |
| | | | | 41-42 | Filter 117 (Steel Blue) | |
| | | | | 43-44 | Filter 118 (Light Blue) | |
| | | | | 45-46 | Filter 119 (Dark Blue) | |
| | | | | 47-48 | Filter 120 (Deep Blue) | |
| | | | | 49-50 | Filter 121 (Filter Green) | |
| | | | | 51-52 | Filter 128 (Bright Pink) | |
| | | | | 53-54 | Filter 131 (Marine Blue) | |
| | | | | 55-56 | Filter 132 (Medium Blue) | |
| | | | | 57-58 | Filter 134 (Golden Amber) | |
| | | | | 59-60 | Filter 135 (Deep Golden Amber) | |
| | | | | 61-62 | Filter 136 (Pale Lavender) | |
| | | | | 63-64 | Filter 137 (Special Lavender) | |
| | | | | 65-66 | Filter 138 (Pale Green) | |
| | | | | 67-68 | Filter 139 (Primary Green) | |
| | | | | 69-70 | Filter 141 (Bright Blue) | |
| | | | | 71-72 | Filter 147 (Apricot) | |
| | | | | 73-74 | Filter 148 (Bright Rose) | |
| | | | | 75-76 | Filter 152 (Pale Gold) | |
| | | | | 77-78 | Filter 154 (Pale Rose) | |
| | | | | 79-80 | Filter 157 (Pink) | |
| | | | | 81-82 | Filter 158 (Deep Orange) | |
| | | | | 83-84 | Filter 162 (Bastard Amber) | |
| | | | | 85-86 | Filter 164 (Flame Red) | |
| | | | | 87-88 | Filter 165 (Daylight Blue) | |
| | | | | 89-90 | Filter 169 (Lilac Tint) | |
| | | | | 91-92 | Filter 170 (Deep Lavender) | |
| | | | | 93-94 | Filter 172 (Lagoon Blue) | |
| | | | | 95-96 | Filter 179 (Chrome Orange) | |
| | | | | 97-98 | Filter 180 (Dark Lavender) | |
| | | | | 99-100 | Filter 181 (Congo Blue) | |
| | | | | 101-102 | Filter 197 (Alice Blue) | |
| | | | | 103-104 | Filter 201 (Full C.T. Blue) | |
| | | | | 105-106 | Filter 202 (Half C.T. Blue) | |
| | | | | 107-108 | Filter 203 (Quarter C.T. Blue) | |
| | | | | 109-110 | Filter 204 (Full C.T. Orange) | |
| | | | | 111-112 | Filter 205 (Half C.T. Orange) | |
| | | | | 113-114 | Filter 206 (Quarter C.T. Orange) | |
| | | | | 115-116 | Filter 247 (Filter Minus Green) | |
| | | | | 117-118 | Filter 248 (Half Minus Green) | |
| | | | | 119-120 | Filter 281 (Three Quarter C.T. Blue) | |
| | | | | 121-122 | Filter 285 (Three Quarter C.T. Orange) | |
| | | | | 123-124 | Filter 352 (Glacier Blue) | |
| | | | | 125-126 | Filter 353 (Lighter Blue) | |
| | | | | 127-128 | Filter 715 (Cabana Blue) | |
| | | | | 129-130 | Filter 778 (Millennium Gold) | |
| | | | | 131-132 | Filter 793 (Vanity Fair) | |
| | | | | | The following 35 multicolours are intended for using with prisma, rot, gobo, or effect wheel only. If none of the three effects is used, the colours will not create multicolour effect. | |
| | | | | 133 | Multicolour 1 /101 Purple Peony | |
| | | | | 134 | Multicolour 2 /104 Magenta | |
| | | | | 135 | Multicolour 3 /105 Peach Pink | |
| | | | | 136 | Multicolour 4 /106 Purple rose | |
| | | | | 137 | Multicolour 5 /107 Bright Crape Myrtle | |
| | | | | 138 | Multicolour 6 /109 Cherry Purple | |
| | | | | 139 | Multicolour 7 /110 Azalea Purple | |
| | | | | 140 | Multicolour 8 /111 Pomegranate Skirt | |
| | | | | 141 | Multicolour 9 /112 Lotus Red | |
| | | | | 142 | Multicolour 10 /113 Wild Rose Pink | |
| | | | | 143 | Multicolour 11 /114 Ravishing Red | |
| | | | | 144 | Multicolour 12 /115 Pink Coral | |
| | | | | 145 | Multicolour 13 /116 Crape Myrtle | |
| | | | | 146 | Multicolour 14 /118 Redbud Purple | |

| 60 Channel | 35 Channel | 64 Channel | 49 Channel | DMX | Function | Note |
|------------|------------|------------|------------|-----|--|------|
| 11 | | 11 | | 147 | Multicolour 15 /119 Light Pink | |
| | | | | 148 | Multicolour 16 /120 Elegant pink | |
| | | | | 149 | Multicolour 17 /121 Light Lilac | |
| | | | | 150 | Multicolour 18 /123 Light Hibiscus | |
| | | | | 151 | Multicolour 19 /124 Root White | |
| | | | | 152 | Multicolour 20 /203 Red Rose | |
| | | | | 153 | Multicolour 21 /208 Dawn Red | |
| | | | | 154 | Multicolour 22 /210 Bright Rose | |
| | | | | 155 | Multicolour 23 /211 Carmine Red | |
| | | | | 156 | Multicolour 24 /212 Sunset Red | |
| | | | | 157 | Multicolour 25 /213 Light Peach Pink | |
| | | | | 158 | Multicolour 26 /214 Ling Xiao | |
| | | | | 159 | Multicolour 27 /216 Light Crimson | |
| | | | | 160 | Multicolour 28 /216 Cherry Red | |
| | | | | 161 | Multicolour 29 /218 Orange Pink | |
| | | | | 162 | Multicolour 30 /220 Begonia Red | |
| | | | | 163 | Multicolour 31 /221 Yang Fei Red | |
| | | | | 164 | Multicolour 32 /222 Apricot White | |
| | | | | 165 | Multicolour 33 /305 Amber | |
| | | | | 166 | Multicolour 34 /308 Realgar | |
| | | | | 167 | Multicolour 35 /309 Sea Breeze Pink | |
| | | | | 168 | Multicolour 36 /311 Light Vermilion | |
| | | | | 169 | Multicolour 37 /312 Light Wheat Yellow | |
| | | | | 170 | Multicolour 38 /405 Bright Amber | |
| | | | | 171 | Multicolour 39 /406 Wheat Yellow | |
| | | | | 172 | Multicolour 40 /407 Tangerine Yellow | |
| | | | | 173 | Multicolour 41 /408 Light Yellow | |
| | | | | 174 | Multicolour 42 /409 Moon White | |
| | | | | 175 | Multicolour 43 /410 Bright Yellow | |
| | | | | 176 | Multicolour 44 /411 Pear Yellow | |
| | | | | 177 | Multicolour 45 /412 Ivory White | |
| | | | | 178 | Multicolour 46 /503 Vivid Green | |
| | | | | 179 | Multicolour 47 /505 Green Mustard | |
| | | | | 180 | Multicolour 48 /506 Chive Yellow | |
| | | | | 181 | Multicolour 49 /507 Bright Yellow-Green | |
| | | | | 182 | Multicolour 50 /508 Pine Pollen Yellow | |
| | | | | 183 | Multicolour 51 /509 Pale White | |
| | | | | 184 | Multicolour 52 /510 Pale Cyan | |
| | | | | 185 | Multicolour 53 /601 Emerald Green | |
| | | | | 186 | Multicolour 54 /609 Verdant | |
| | | | | 187 | Multicolour 55 /610 Light Emerald Blue | |
| | | | | 188 | Multicolour 56 /611 Jade Green | |
| | | | | 189 | Multicolour 57 /612 lotus Green | |
| | | | | 190 | Multicolour 58 /613 Apple Green | |
| | | | | 191 | Multicolour 59 /614 Emerald-Tinted Green | |
| | | | | 192 | Multicolour 60 /615 Cerulean Blue | |
| | | | | 193 | Multicolour 61 /616 Mint Green | |
| | | | | 194 | Multicolour 62 /707 Indigo Blue | |
| | | | | 195 | Multicolour 63 /708 Light Green | |
| | | | | 196 | Multicolour 64 /710 Turquoise Green | |
| | | | | 197 | Multicolour 65 /711 Sinomenium acutum | |
| | | | | 198 | Multicolour 66 /713 Blue-Green | |
| | | | | 199 | Multicolour 67 /714 Sky Blue | |
| | | | | 200 | Multicolour 68 /715 Cloudy Water Blue | |
| | | | | 201 | Multicolour 69 /716 Light Ink Blue | |
| | | | | 202 | Multicolour 70 /717 Light Blue | |
| | | | | 203 | 719 Azure | |
| | | | | 204 | 720 Smoke Cyan | |
| | | | | 205 | 721 Cyan Grey | |
| | | | | 206 | 801 Deep Blue | |
| | | | | 207 | 807 Ink Blue | |
| | | | | 208 | 808 Pale Cyan | |
| | | | | 209 | 813 Steel Blue | |
| | | | | 210 | 814 Bright Blue | |
| | | | | 211 | 815 Cyan Cloud | |
| | | | | 212 | 902 Peacock Blue | |
| | | | | 213 | 903 Dark Lavender | |
| | | | | 214 | 904 Violet | |
| | | | | 215 | 906 February orchid | |
| | | | | 216 | 907 Lapis Lazuli Blue | |
| | | | | 217 | 908 Dusk Purple | |
| | | | | 218 | 909 Foggy Slate | |
| | | | | 219 | 910 Medium Lavender | |
| | | | | 220 | 911 Lavender | |
| | | | | 221 | 912 Light Lavender | |
| | | | | 222 | 1004 Datura Purple | |
| | | | | 223 | 1005 Cherry Blossom Purple | |
| | | | | 224 | 1006 Luxury Purple | |
| | | | | 225 | 1007 Imperial Purple | |

| 60 Channel | 35 Channel | 64 Channel | 49 Channel | DMX | Function | Note |
|------------|------------|------------|------------|---------|---|------|
| | | | | 226 | 1010 Bellflower Purple | |
| | | | | 227 | 1011 Lotus Purple | |
| | | | | 228 | 1012 NI SHANG Purple | |
| | | | | 229 | 1013 Strong Purple | |
| | | | | 230 | 1015 Fei Purple | |
| | | | | 231 | 1017 Silver Pink | |
| | | | | 232-233 | User colour 9 | |
| | | | | 234-235 | User colour 10 | |
| | | | | 236-245 | Rainbow effect (with fade time) from slow-> fast | |
| | | | | 246-255 | Rainbow effect (without fade time) from slow-> fast | |
| | | | | | Virtual Colour wheel (Use in Compatible Mode 49CH) | |
| | | | | 0 | No function | |
| | | | | 1-2 | Filter 4 (Medium Bastard Amber) | |
| | | | | 3-4 | Filter 10 (Medium Yellow) | |
| | | | | 5-6 | Filter 19 (Fire) | |
| | | | | 7-8 | Filter 26 (Bright Red) | |
| | | | | 9-10 | Filter 58 (Lavender) | |
| | | | | 11-12 | Filter 68 (Sky Blue) | |
| | | | | 13-14 | Filter 71 (Tokyo Blue) | |
| | | | | 15-16 | Filter 79 (Just Blue) | |
| | | | | 17-18 | Filter 88 (Lime Green) | |
| | | | | 19-20 | Filter 90 (Dark Yellow Green) | |
| | | | | 21-22 | Filter 100 (Spring Yellow) | |
| | | | | 23-24 | Filter 101 (Yellow) | |
| | | | | 25-26 | Filter 102 (Light Amber) | |
| | | | | 27-28 | Filter 103 (Straw) | |
| | | | | 29-30 | Filter 104 (Deep Amber) | |
| | | | | 31-32 | Filter 105 (Orange) | |
| | | | | 33-34 | Filter 106 (Primary Red) | |
| | | | | 35-36 | Filter 111 (Dark Pink) | |
| | | | | 37-38 | Filter 115 (Peacock Blue) | |
| | | | | 39-40 | Filter 116 (Medium Blue-Green) | |
| | | | | 41-42 | Filter 117 (Steel Blue) | |
| | | | | 43-44 | Filter 118 (Light Blue) | |
| | | | | 45-46 | Filter 119 (Dark Blue) | |
| | | | | 47-48 | Filter 120 (Deep Blue) | |
| | | | | 49-50 | Filter 121 (Filter Green) | |
| | | | | 51-52 | Filter 128 (Bright Pink) | |
| | | | | 53-54 | Filter 131 (Marine Blue) | |
| | | | | 55-56 | Filter 132 (Medium Blue) | |
| | | | | 57-58 | Filter 134 (Golden Amber) | |
| | | | | 59-60 | Filter 135 (Deep Golden Amber) | |
| | | | | 61-62 | Filter 136 (Pale Lavender) | |
| | | | | 63-64 | Filter 137 (Special Lavender) | |
| | | | | 65-66 | Filter 138 (Pale Green) | |
| | | | | 67-68 | Filter 139 (Primary Green) | |
| | | | | 69-70 | Filter 141 (Bright Blue) | |
| | | | | 71-72 | Filter 147 (Apricot) | |
| | | | | 73-74 | Filter 148 (Bright Rose) | |
| | | | | 75-76 | Filter 152 (Pale Gold) | |
| | | | | 77-78 | Filter 154 (Pale Rose) | |
| | | | | 79-80 | Filter 157 (Pink) | |
| | | | | 81-82 | Filter 158 (Deep Orange) | |
| | | | | 83-84 | Filter 162 (Bastard Amber) | |
| | | | | 85-86 | Filter 164 (Flame Red) | |
| | | | | 87-88 | Filter 165 (Daylight Blue) | |
| | | | | 89-90 | Filter 169 (Lilac Tint) | |
| | | | | 91-92 | Filter 170 (Deep Lavender) | |
| | | | | 93-94 | Filter 172 (Lagoon Blue) | |
| | | | | 95-96 | Filter 179 (Chrome Orange) | |
| | | | | 97-98 | Filter 180 (Dark Lavender) | |
| | | | | 99-100 | Filter 181 (Congo Blue) | |
| | | | | 101-102 | Filter 197 (Alice Blue) | |
| | | | | 103-104 | Filter 201 (Full C.T. Blue) | |
| | | | | 105-106 | Filter 202 (Half C.T. Blue) | |
| | | | | 107-108 | Filter 203 (Quarter C.T. Blue) | |
| | | | | 109-110 | Filter 204 (Full C.T. Orange) | |
| | | | | 111-112 | Filter 205 (Half C.T. Orange) | |
| | | | | 113-114 | Filter 206 (Quarter C.T. Orange) | |
| | | | | 115-116 | Filter 247 (Filter Minus Green) | |
| | | | | 117-118 | Filter 248 (Half Minus Green) | |
| | | | | 119-120 | Filter 281 (Three Quarter C.T. Blue) | |
| | | | | 121-122 | Filter 285 (Three Quarter C.T. Orange) | |
| | | | | 123-124 | Filter 352 (Glacier Blue) | |
| | | | | 125-126 | Filter 353 (Lighter Blue) | |
| | | | | 127-128 | Filter 715 (Cabana Blue) | |

| 60 Channel | 35 Channel | 64 Channel | 49 Channel | DMX | Function | Note |
|------------|------------|------------|------------|---------|---|------|
| | | | | 129-130 | Filter 778 (Millennium Gold) | |
| | | | | 131-132 | Filter 793 (Vanity Fair) | |
| | | | | | The following 35 multicolours are intended for using with prisma, rot, gobo, or effect wheel only. if none of the three effects is used, the colours will not create multicolour effect. | |
| | | | | 133 | Multicolour 1 | |
| | | | | 134 | Multicolour 2 | |
| | | | | 135 | Multicolour 3 | |
| | | | | 136 | Multicolour 4 | |
| | | | | 137 | Multicolour 5 | |
| | | | | 138 | Multicolour 6 | |
| / | / | / | 11 | 139 | Multicolour 7 | |
| | | | | 140 | Multicolour 8 | |
| | | | | 141 | Multicolour 9 | |
| | | | | 142 | Multicolour 10 | |
| | | | | 143 | Multicolour 11 | |
| | | | | 144 | Multicolour 12 | |
| | | | | 145 | Multicolour 13 | |
| | | | | 146 | Multicolour 14 | |
| | | | | 147 | Multicolour 15 | |
| | | | | 148 | Multicolour 16 | |
| | | | | 149 | Multicolour 17 | |
| | | | | 150 | Multicolour 18 | |
| | | | | 151 | Multicolour 19 | |
| | | | | 152 | Multicolour 20 | |
| | | | | 153 | Multicolour 21 | |
| | | | | 154 | Multicolour 22 | |
| | | | | 155 | Multicolour 23 | |
| | | | | 156 | Multicolour 24 | |
| | | | | 157 | Multicolour 25 | |
| | | | | 158 | Multicolour 26 | |
| | | | | 159 | Multicolour 27 | |
| | | | | 160 | Multicolour 28 | |
| | | | | 161 | Multicolour 29 | |
| | | | | 162 | Multicolour 30 | |
| | | | | 163 | Multicolour 31 | |
| | | | | 164 | Multicolour 32 | |
| | | | | 165 | Multicolour 33 | |
| | | | | 166 | Multicolour 34 | |
| | | | | 167 | Multicolour 35 | |
| | | | | 168 | Multicolour 36 | |
| | | | | 169 | Multicolour 37 | |
| | | | | 170 | Multicolour 38 | |
| | | | | 171 | Multicolour 39 | |
| | | | | 172 | Multicolour 40 | |
| | | | | 173 | Multicolour 41 | |
| | | | | 174 | Multicolour 42 | |
| | | | | 175 | Multicolour 43 | |
| | | | | 176 | Multicolour 44 | |
| | | | | 177 | Multicolour 45 | |
| | | | | 178 | Multicolour 46 | |
| | | | | 179 | Multicolour 47 | |
| | | | | 180 | Multicolour 48 | |
| | | | | 181 | Multicolour 49 | |
| | | | | 182 | Multicolour 50 | |
| | | | | 183 | Multicolour 51 | |
| | | | | 184 | Multicolour 52 | |
| | | | | 185 | Multicolour 53 | |
| | | | | 186 | Multicolour 54 | |
| | | | | 187 | Multicolour 55 | |
| | | | | 188 | Multicolour 56 | |
| | | | | 189 | Multicolour 57 | |
| | | | | 190 | Multicolour 58 | |
| | | | | 191 | Multicolour 59 | |
| | | | | 192 | Multicolour 60 | |
| | | | | 193 | Multicolour 61 | |
| | | | | 194 | Multicolour 62 | |
| | | | | 195 | Multicolour 63 | |
| | | | | 196 | Multicolour 64 | |
| | | | | 197 | Multicolour 65 | |
| | | | | 198 | Multicolour 66 | |
| | | | | 199 | Multicolour 67 | |
| | | | | 200 | Multicolour 68 | |
| | | | | 201 | Multicolour 69 | |
| | | | | 202 | Multicolour 70 | |

| 60 Channel | 35 Channel | 64 Channel | 49 Channel | DMX | Function | Note |
|------------|------------|------------|------------|--|---|------|
| | | | | 203-215 | Reserved | |
| | | | | 216-217 | User colour 1 | |
| | | | | 218-219 | User colour 2 | |
| | | | | 220-221 | User colour 3 | |
| | | | | 222-223 | User colour 4 | |
| | | | | 224-225 | User colour 5 | |
| | | | | 226-227 | User colour 6 | |
| | | | | 228-229 | User colour 7 | |
| | | | | 230-231 | User colour 8 | |
| | | | | 232-233 | User colour 9 | |
| | | | | 234-235 | User colour 10 | |
| | | | | 236-245 | Rainbow effect (with fade time) from slow-> fast | |
| | | | | 246-255 | Rainbow effect (without fade time) from slow-> fast | |
| 12 | 9 | / | 12 | 0-255 | Cyan /Red Cyan/Red 0%-100% | |
| 13 | / | / | 13 | 0-255 | Cyan Fine/Red Fine Cyan fine/Red fine 0%-100% | |
| 14 | 10 | / | 14 | 0-255 | Magenta/Green Magenta/Green 0%-100% | |
| 15 | / | / | 15 | 0-255 | Magenta Fine /Green Fine Magenta fine/Green fine 0%-100% | |
| 16 | 11 | / | 16 | 0-255 | Yellow/Blue Yellow/Blue 0%-100% | |
| 17 | / | / | 17 | 0--255 | Yellow Fine /Blue Fine Yellow fine/Blue fine 0%-100% | |
| / | / | 12 | / | 0-255 | Red Red 0%-100% | |
| / | / | 13 | / | 0-255 | Red Fine Red fine 0%-100% | |
| / | / | 14 | / | 0-255 | Green Green 0%-100% | |
| / | / | 15 | / | 0-255 | Green Fine Magenta fine/Green fine 0%-100% | |
| / | / | 16 | / | 0-255 | Blue Blue 0%-100% | |
| / | / | 17 | / | 0-255 | Blue Fine Blue fine 0%-100% | |
| / | / | 18 | / | 0-255 | Amber Amber 0%-100% | |
| / | / | 19 | / | 0-255 | Amber Fine Amber fine 0%-100% | |
| / | / | 20 | / | 0-255 | Light Green Light Green 0%-100% | |
| / | / | 21 | / | 0-255 | Light Green Fine Light Green fine 0%-100% | |
| 18 | 12 | 22 | 18 | 0-1 2-64 65 66-109 110 111-179 180 181-229 230 231-254 255 | Colour temperature correction (CTC) 8000K Colour temperature changing 7978 K -->6622 K (22 K /1 DMX) 6600 K Colour temperature changing 657 8K -->5622 K (22 K/1 DMX) 5600 K (110=default) Colour temperature changing 5580 K -->4220 K (20 K/1 DMX) 4200 K Colour temperature changing 4180 K -->3220 K (20 K/1 DMX) 3200 K Colour temperature changing 3180 K -->2720 K (20K /1 DMX) 2700K | |
| 19 | / | 23 | 19 | 0 1-127 128 129-254 255 | Green correction Uncorrected white Minus green --> uncorrected white Uncorrected white (128=default) Uncorrected white --> Plus green Uncorrected white | |
| 20 | / | 24 | 20 | 0-9 10-19 20-29 30-39 40-49 50-59 60-69 70-79 80-128 | Colour mix control Defines relation between Virtual Colour wheel and colour channels:"Virtual" = Virtual Colour Wheel*Colour mix* = Colour channels (CMY/RGBALight Green/CTC) Virtual has priority over "Colour mix" (0=default) Maximum mode (highest values have priority) Minimum mode (lowest values have priority) Multiply mode (multiply "Virtual" and "Colour mix") Addition mode ("Virtual" + "Colour mix") Subtraction mode ("Virtual" - "Colour mix") Inverted Subtraction mode ("Colour mix"- "Virtual") White Point Off (CTC+Green Cor.+Virtual Colour Wheel deactivated) Reserved | |

| 60 Channel | 35 Channel | 64 Channel | 49 Channel | DMX | Function | Note |
|------------|------------|------------|------------|---|--|-------------------------|
| | | | | 129 130-254 255 | Crossfade "Virtual" only Crossfade between "Virtual" and "Colour mix" Crossfade "Colour mix" only | |
| 21 | / | 25 | 21 | 0-255 | Speed of rot. Gobo selection Speed of rot. gobo selection from max. to min. (0=default) | |
| 22 | / | 26 | 22 | 0 1-255 1-255 1-50 | Rot. Gobo carousel/ Framing shutters/Zoom/Focus/Iris/Frost/Prism time Function is off (0=default) Time of rot. Gobo carousel movement (0.1 sec-->25.5 sec.) Time of framing shutters, zoom, focus, iris and frost movement (0.1sec-->25.5 sec.) Time of prism movement (0.1 sec-->5 sec.) | Temporarily ineffective |
| 23 | 13 | 27 | 23 | 0-19 20-127 128-170 171-213 214-255 | Effect No function (0=default) Proportional indexing (73-center) Ramping from open to full position (max---->min. speed) Ramping from open to half position (max. --->min. speed) Ramp. from half position to full position (max. -->min. speed) | |
| 24 | 14 | 28 | 24 | 0 1-127 128 129-255 | Effect Rotation No Function Forwards rotation from fast to slow No rotation (128=default) Backwards rotation from fast to slow | |
| 25 | / | 29 | 25 | 0-7 8-9 10-11 12-13 14-15 16-17 18-19 20-21 22-23 24-25 26-27 28-29 30-31 32-33 34-35 36-37 38-39 40-41 42-43 44-45 46-47 48-255 | Effect wheel animations No animation (0=default) Note : Set suitable DMX value at Focus channel to get desired animation. All animations were created at distance of 5 m from screen with zoom=88 DMX, Focus value is different for each effect (focus value is stated in parentheses for this distance) The following channels are blocked: Effect wheel positioning, Effect wheel rotation, Rotating gobo wheel, Rot. Gobo indexing and rotation. Macro 1 (Focus=94) Macro 2 (Focus=95) Macro 3 (Focus=96) Macro 4 (Focus=97) Macro 5 (Focus=98) Macro 6 (Focus=99) Macro 7 (Focus=100) Macro 8 (Focus=101) Macro 9 (Focus=102) Macro 10 (Focus=103) Macro 11 (Focus=103) Macro 12 (Focus=103) Macro 13 (Focus=103) Macro 14 (Focus=103) Macro 15 (Focus=103) Macro 16 (Focus=103) Macro 17 (Focus=103) Macro 18 (Focus=103) Macro 19 (Focus=103) Macro 20 (Focus=103) Reserved | |
| 26 | 15 | 30 | 26 | 0-3 4-7 8-11 12-15 16-19 20-23 24-27 28-31 32-35 36-39 40-43 44-47 48-51 52-55 56-59 60-69 70-79 80-89 | Rotating gobo wheel Index - set indexing on channel 27/16/31/27 Open/hole (0=default) Gobo 1 Gobo 2 Gobo 3 Gobo 4 Gobo 5 Gobo 6 Gobo 7 Rotation - set rotation on channel 27/16/31/27 Gobo 1 Gobo 2 Gobo 3 Gobo 4 Gobo 5 Gobo 6 Gobo 7 Shaking gobos from slow to fast Index - set Indexing on channel 27/16/31/27 Gobo 1 Gobo 2 Gobo 3 | |

| 60 Channel | 35 Channel | 64 Channel | 49 Channel | DMX | Function | Note |
|------------|------------|------------|------------|---|--|------|
| | | | | 90-99 100-109 110-119 120-129 130-139 140-149 150-159 160-169 170-179 180-189 190-199 200-201 202-222 223-243 244-249 250-255 | Gobo 4 Gobo 5 Gobo 6 Gobo 7 Shaking gobos from slow to fast Rotation - set rotation on channel 27/16/31/27 Gobo 1 Gobo 2 Gobo 3 Gobo 4 Gobo 5 Gobo 6 Gobo 7 Open/hole Forwards gobo wheel rotation from fast to slow Backwards gobo wheel rotation from slow to fast Stop Auto random gobo selection from fast to slow | |
| 27 | 16 | 31 | 27 | 0-255 0 1-127 128 129-255 | Rot. gobo Indexing and rotation Gobo Indexing - set position on channel 26/15/30/26 Gobo indexing (128=default) Gobo rotation - set position on channel 26/15/30/26 No rotation Forwards gobo rotation from fast to slow No rotation (128=default) Backwards gobo rotation from slow to fast | |
| 28 | / | 32 | 28 | 0-255 | Rot. gobo Indexing/rotation - fine Fine indexing/rotation (0=default) | |
| 29 | 17 | 33 | / | 0-3 4-7 8-11 12-15 16-19 20-23 24-27 28-31 32-35 36-39 40-43 44-47 48-51 52-55 56-59 60-69 70-79 80-89 90-99 100-109 110-119 120-129 130-139 140-149 150-159 160-169 170-179 180-189 190-199 200-201 202-222 223-243 244-249 250-255 | Rotating gobo wheel2 Index - set indexing on channel 30/18/34 Open/hole (0=default) Gobo 1 Gobo 2 Gobo 3 Gobo 4 Gobo 5 Gobo 6 Gobo 7 Rotation - set rotation on channel 30/18/34 Gobo 1 Gobo 2 Gobo 3 Gobo 4 Gobo 5 Gobo 6 Gobo 7 Shaking gobos from slow to fast Index - set indexing on channel 30/18/34 Gobo 1 Gobo 2 Gobo 3 Gobo 4 Gobo 5 Gobo 6 Gobo 7 Shaking gobos from slow to fast Rotation - set rotation on channel 30/18/34 Gobo 1 Gobo 2 Gobo 3 Gobo 4 Gobo 5 Gobo 6 Gobo 7 Open/hole Forwards gobo wheel rotation from fast to slow Backwards gobo wheel rotation from slow to fast Reserved Auto random gobo selection from fast to slow | |
| 30 | 18 | 34 | / | 0-255 0 1-127 128 129-255 | Rot. gobo2 Indexing and rotation Gobo Indexing - set position on channel 29/17/33 Gobo indexing (128=default) Gobo rotation - set position on channel 29/17/33 No rotation Forwards gobo rotation from fast to slow No rotation (128=default) Backwards gobo rotation from slow to fast | |
| 31 | / | 35 | / | 0-255 | Rot. gobo2 Indexing/rotation - fine Fine indexing/rrotation (0=default) | |

| 60 Channel | 35 Channel | 64 Channel | 49 Channel | DMX | Function | Note |
|------------|------------|------------|------------|--|--|------|
| 32 | 19 | 36 | 29 | 0-19 20-127 128-135 136-143 144-151 152-159 160-167 168-175 176-183 184-191 192-199 200-207 208-215 216-223 224-231 232-239 240-247 248-255 | Prism Open position - hole (0=default) Rotating prism inserted Prism/gobo macros: The following channels are blocked: Prism, Prism rotation, Rotating gobo wheel, Rot. Gobo indexing and rotation. Macro 1 Macro 2 Macro 3 Macro 4 Macro 5 Macro 6 Macro 7 Macro 8 Macro 9 Macro 10 Macro 11 Macro 12 Macro 13 Macro 14 Macro 15 Macro 16 | |
| 33 | 20 | 37 | 30 | 0 1-127 128 129-255 | Prism rotation No Function Forwards prism rotation from fast to slow No rotation (128=default) Backwards prism rotation from slow to fast | |
| 34 | 21 | 38 | 31 | 0 1-50 51-53 54-63 64-73 74-83 84-86 87-136 137-139 140-149 150-159 160-169 170-172 173-222 223-225 226-235 236-245 246-255 | Frost Open (0=default) Light Frost Light Frost from 0% to 100% 100% Light Frost Pulse closing from slow to fast Pulse opening from fast to slow Ramping from fast to slow Open Medium Frost Medium Frost from 0% to 100% 100% Medium Frost Pulse closing from slow to fast Pulse opening from fast to slow Ramping from fast to slow Open Combined Frost Medium Frost from 0% to 100% 100% Medium Frost Pulse closing from slow to fast Pulse opening from fast to slow Ramping from fast to slow | |
| 35 | 22 | 39 | 32 | 0 1-179 180-191 192-219 220-247 248-249 250-251 252-253 254-255 | Iris Open (0=default) From max.diameter to min.diameter Closed Pulse effects with Iris blackout Pulse opening from slow to fast Pulse closing from fast to slow Random pulse opening (fast) Random pulse opening (slow) Random pulse closing (fast) Random pulse closing (slow) | |
| 36 | / | 40 | 33 | 0-255 | Iris - fine Fine Iris movement (0=default) | |
| 37 | 23 | 41 | 34 | 0-255 | Zoom Zoom from max. to min.beam angle (128=default) | |
| 38 | / | 42 | 35 | 0-255 | ZoomFine Fine Zoom positioning | |
| 39 | 24 | 43 | 36 | 0-255 | Focus Continuous adjustment from far to near (128=default) | |
| 40 | / | 44 | 37 | 0-255 | Focus Fine Fine Focus positioning | |
| 41 | 25 | 45 | 38 | 0-127 128 129-255 | Framing Rotation Rotation from right (0°) to 60° Center (128=default) Rotation from 60° to left (120°) | |
| 42 | 26 | 46 | 39 | 0-255 | Framing shutter 1- movement Movement from Outward to inward (0=default) | |

| 60 Channel | 35 Channel | 64 Channel | 49 Channel | DMX | Function | Note |
|------------|------------|------------|------------|---|--|------|
| 43 | / | 47 | / | 0-255 | Framing shutter 1 fine- movement fine Movement from Outward to Inward (0=default) | |
| 44 | 27 | 48 | 40 | 0-127 128 0 degrees (128=default) 0-255 | Framing shutter 1- swivelling Swivelling towards 0 degrees 0 degrees (128=default) Swivelling from 0 degrees | |
| 45 | / | 49 | / | 0-127 128 0 degrees (128=default) 0-255 | Framing shutter 1 fine- swivelling fine Swivelling towards 0 degrees 0 degrees (128=default) Swivelling from 0 degrees | |
| 46 | 28 | 50 | 41 | 0-255 | Framing shutter 2- movement Movement from Outward to Inward (0=default) | |
| 47 | / | 51 | / | 0-255 | Framing shutter 2 fine- movement fine Movement from Outward to Inward (0=default) | |
| 48 | 29 | 52 | 42 | 0-127 128 0 degrees (128=default) 0-255 | Framing shutter 2- swivelling Swivelling towards 0 degrees 0 degrees (128=default) Swivelling from 0 degrees | |
| 49 | / | 53 | / | 0-127 128 0 degrees (128=default) 0-255 | Framing shutter 2 fine- swivelling fine Swivelling towards 0 degrees 0 degrees (128=default) Swivelling from 0 degrees | |
| 50 | 30 | 54 | 43 | 0-255 | Framing shutter 3- movement Movement from Outward to Inward (0=default) | |
| 51 | / | 55 | / | 0-255 | Framing shutter 3 fine- movement fine Movement from Outward to Inward (0=default) | |
| 52 | 31 | 56 | 44 | 0-127 128 0 degrees (128=default) 0-255 | Framing shutter 3- swivelling Swivelling towards 0 degrees 0 degrees (128=default) Swivelling from 0 degrees | |
| 53 | / | 57 | / | 0-127 128 0 degrees (128=default) 0-255 | Framing shutter 3 fine- swivelling fine Swivelling towards 0 degrees 0 degrees (128=default) Swivelling from 0 degrees | |
| 54 | 32 | 58 | 45 | 0-255 | Framing shutter 4- movement Movement from Outward to Inward (0=default) | |
| 55 | / | 59 | / | 0-255 | Framing shutter 4 fine- movement fine Movement from Outward to Inward (0=default) | |
| 56 | 33 | 60 | 46 | 0-127 128 0 degrees (128=default) 0-255 | Framing shutter 4- swivelling Swivelling towards 0 degrees 0 degrees (128=default) Swivelling from 0 degrees | |
| 57 | / | 61 | / | 0-127 128 0 degrees (128=default) 0-255 | Framing shutter 4 fine- swivelling fine Swivelling towards 0 degrees 0 degrees (128=default) Swivelling from 0 degrees | |
| 58 | 34 | 62 | 47 | 0-31 32-63 64-95 96-127 128-143 144-159 160-191 192-223 224-255 | Shutter/ strobe Shutter closed Shutter open (32=default) Strobe-effect from slow to fast Shutter open Opening pulse in sequences from slow to fast Closing pulse in sequences from fast to slow Shutter open Random strobe-effect from slow to fast Shutter open | |
| 59 | 35 | 63 | 48 | 0-255 | Dimmer Dimmer intensity from 0% to 100% (0=default) | |
| 60 | / | 64 | 49 | 0-255 | Dimmer Fine Dimmer Fine | |

7. Electrical Connection Diagram

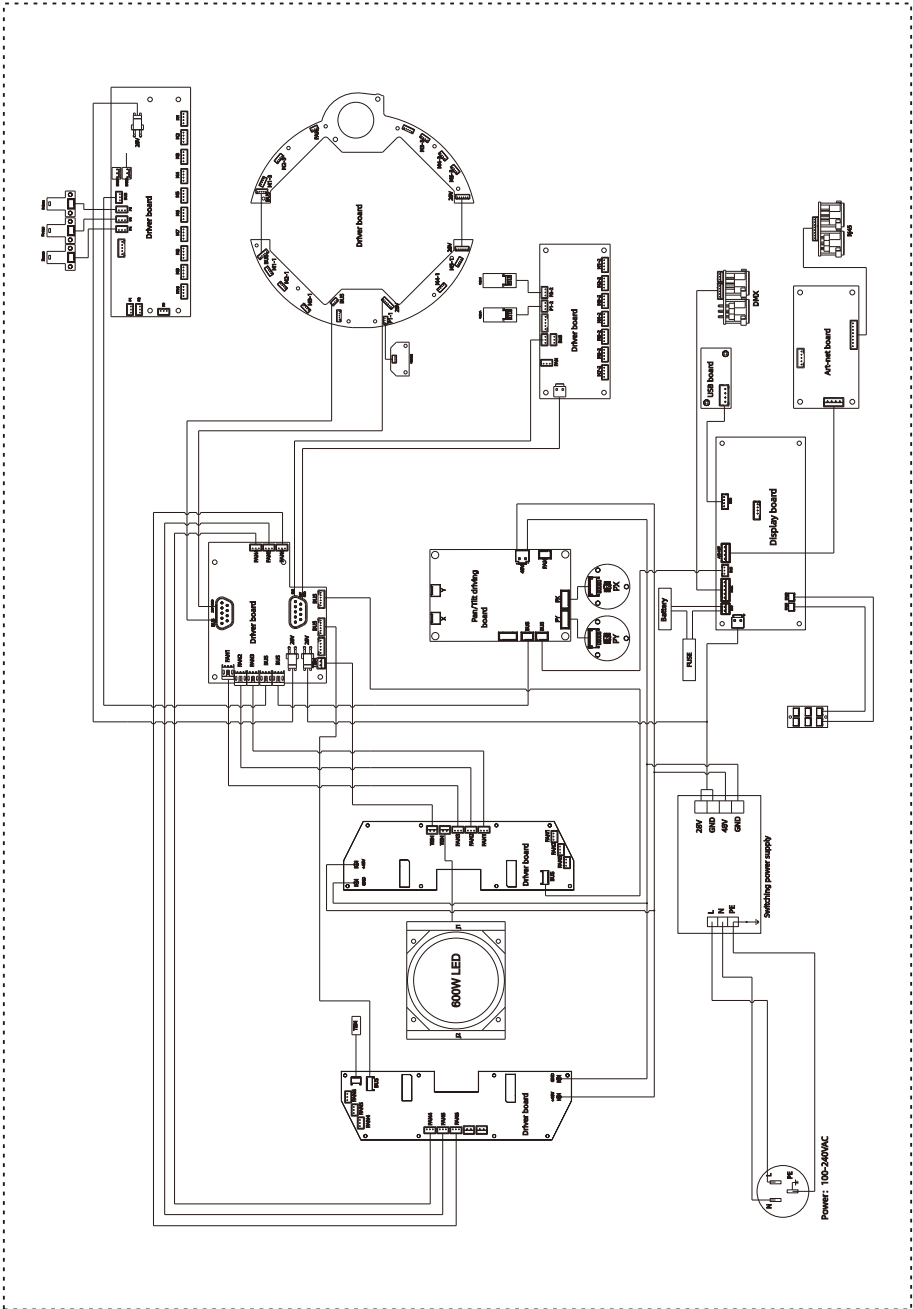

8. Troubleshooting

The following are common faults of lamps and corresponding solutions. Faults that cannot be repaired by yourself should be handled by professionally qualified personnel. Disconnect the power supply to the lamp during maintenance!

- The light source is not bright
 - Check that a suitable light source is installed for the luminaire.
 - Check whether the power supply connection of the lamp or the control switch is in poor contact.
 - Check whether the light source has reached the end of its service life or is damaged, and replace it with a high-quality light source of the same specification.
 - Measure whether the power supply is insufficient.
 - Check whether the light source has not cooled down completely due to abnormal operation. Let the lamp cool down for more than 15 minutes to allow the light source to cool down. After returning to the normal start-up range, turn the power on again and it can be used normally.
 - Check whether the DMX512 controller sends a command to turn on the light source.
 - Check whether the light source and trigger circuit are disconnected or defective.
 - Check whether the wiring terminals on the internal trigger are in poor contact and tighten the plug.
 - Check the "Fan Speed and Voltage" in the "Basic Information" menu to see if the speed of FAN1/FAN2/FAN3 is above 500RPN. If it is below 500RPM, the light source will not light up. Replace the fan with the same specification.
 - Check whether the over-temperature protection temperature switch inside the lamp is damaged. Go to the menu "Basic Information" and select "Equipment Temperature" to check - whether the temperature measuring plate shows that the temperature is too high or there is no temperature display.
- The beam appears dim and uneven
 - The light source may have reached the end of its service life and does not emit enough light. Replace it with a light source of the same specification.
 - Check whether there is dust accumulated in the optical part and clean it.
 - Measure whether the power supply is insufficient.
 - Finely adjust the screw device used to change the height of the lamp until the ideal light is achieved. Enter the menu "Service Options" and select "Calibration" to enter color and pattern adjustment, which can be adjusted to the center.
- The projected image is blurry
 - Check whether the DMX512 controller channel value corresponding to the electronic focus system is suitable for the current projection distance.
 - Check whether the mechanical part of the focusing system is stuck, remove the dust and add antifreeze and temperature-resistant lubricating oil.
- The light source of the lamp works intermittently
 - Check whether the fan is running normally or is blocked by dust and paper debris.
 - Check whether the inlet and outlet cooling air vents are blocked by dust.
 - Check whether the lamp has reached the end of its service life.

- Check whether the power supply is insufficient, and whether the power switch and wiring are in poor contact or aging.
- Check whether the over-temperature protection temperature switch inside the lamp is damaged.
- Although it emits light, the lamp does not accept instructions from the controller
- Check whether the digital start address value and function options of the lamp are correct.
- Check whether the connection of the communication control line is correct. The communication line is too long or has been interrupted.
- Check whether the control equipment fails and whether the signal amplifier connected in series fails.
- Check whether the communication line is too long or if other devices interfere with each other.
- Optimize wiring, shorten the length of control signal lines, and route high-voltage and low-voltage lines separately
- Add signal amplifier isolator.
- The signal line is made of high-quality shielded twisted pair (impedance characteristic is 75Ω), and the signal terminal resistor is connected at the end of the lamp.
- Check that the circuit board communication IC or CPU is burned out because the bulb performs an abnormal operation when it is not completely cooled, causing the instantaneous ultra-high voltage leakage generated by the trigger, and replace the PCB board.
- The lamp cannot be started
- Check whether the power supply parameters match the lamps.
- Check whether the fuse at the light fixture's power input is blown.
- Check that the lamp has poor contact or falls off due to extrusion deformation, vibration of internal parts, moisture, etc. during long-distance transportation.
- Check whether the internal wires and connectors of the lamp are desoldered or loose.
- Check whether the electrical components of the lamp (such as power switch, transformer, ballast, capacitor, varistor, filter, power supply PCB board, motor control PCB board, etc.) are loose, short-circuited, burned out, etc.
- Some functions of the lamp cannot accept controller instructions
- Check whether the control device sends correct action instructions for these functions.
- Check whether the mechanical parts corresponding to these functions are loose or deformed.
- Check whether the motor sockets corresponding to these functions are loose or the corresponding driver chips are burned out.
- Check whether the motor wires corresponding to these functions are broken at the corners.
- Check whether the motors corresponding to these functions are damaged.
- During operation, the X or Y direction of the lamp does not move normally
- Click the previous step to check one by one.
- Check whether the corresponding drive belts in the X and Y directions of the lamp are detached or broken.
- Check whether the data feedback receiver corresponding to the X and Y directions in the lamp is damaged.
- Restart the computer and reset it once.

9. Fixture Cleaning

It is absolutely essential that the fixture is kept clean to ensure the maximum light-output and allow the fixture to function reliably throughout its life. The fixture must be cleaned regularly to avoid dust, dirt and smoke-fluid residues building up on or within the fixture. The cleaning frequency depends on the application environment. Clean the fixture immediately if the dust enters it to avoid damage to the optical lens due to excessive dust.

- A soft lint-free cloth moistened with any good glass cleaning fluid is recommended, under no circumstances should solvents be used.
- Always dry the parts carefully.
- Clean the external optical lens at least every 20 days .



CAUTION ! ! !

Disconnect from mains before starting maintenance operation.

10. Duty exonerative and copyright protectio

- Light source belongs to consumption products, not within the scope of warranty.
- The manufacturer shall not bear any responsibility for any damage caused by failure to operate in accordance with this instruction.
- The manufacturer reserves the right of final interpretation for all information in this manual. For any questions, please refer to the official website.
- All the information in this manual shall not be copied without permission.
- The data contained in this statement are subject to change in the future without prior notice.