

# LIGHT SKY

[www.lightsky.com.cn](http://www.lightsky.com.cn)

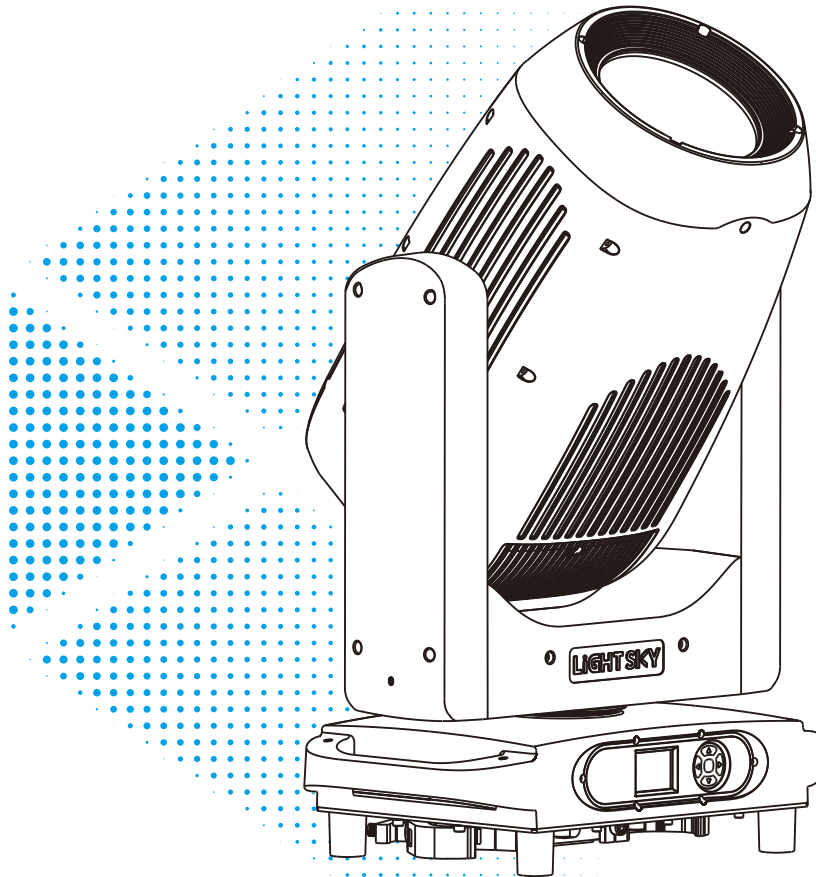

## **SUPER SCOPE AQUA** User Manual

Please read the instruction carefully before use

**Fly Dragon Lighting Equipment Co., Ltd.**

Add : NO.4 JINGNENG ROAD 1, HUADU DISTRICT, GUANGZHOU, CHINA.  
Tel : 020-61828288 Fax : 020-61828188 Postal Code : 510820  
Email : flydragon@lightsky.com.cn



Social Media



LIGHT SKY Wechat

# CONTENTS

1. Safety Instructions .....	2
2. Technical Specifications .....	5
2.1. Attachment And Size .....	8
3. Color/Gobo/Prism .....	10
4. Control Panel.....	11
5. Connection and control.....	12
5.1. Power supply connection .....	12
5.2. DMX 512 Connection .....	13
6. How To Set The Unit .....	14
6.1. Main Function.....	14
6.2. Address Setting .....	18
6.3. DMX 512 Configuration .....	19
7. Electrical Connection Diagram .....	29
8. Troubleshooting .....	30
9. Fixture Cleaning .....	32
10. Duty exonerative and copyright protectio .....	32

**Congratulations on choosing our company product! We thank you for your custom.**

- Please keep in mind that this product, like other products of the company, adheres to the concept of people-oriented design and manufacture, and takes product quality as the foundation.
- We put the interests of customers first, and do our best to meet customer requirements.
- Please read this instruction manual carefully and keep it for future reference. In the case of fully understanding the product information, strictly abide by theUse the instruction manual to ensure that the product is installed, used and serviced correctly and safely.
- Our company is not responsible for any damage to lamps or other performance due to personal failure to follow the instructions during installation, use and maintenance.responsibility.
- Our company reserves the right to modify the manual at any time and without prior notice.

## 1.Safety Instructions



**WARNING**

Please read the instruction carefully which includes important information about the installation, usage and maintenance.

Please keep this User Manual for future consultation. If you sell the unit to another user, be sure that they also receive this manual.

The following symbols are used to identify important safety information on the product and in this manual:

<b>WARNING!</b> Safety hazard. Risk of severe injury or death.	<b>WARNING!</b> Refer to manual before installing, powering or servicing.	<b>WARNING!</b> Hazardous voltage. Risk of severe or lethal electric shock.	<b>WARNING!</b> Fire hazard.	<b>WARNING!</b> Burn hazard. Hot surface, not touch. Do not touch	<b>WARNING!</b> Risk of eye injury. Safety glasses must be worn.	<b>WARNING!</b> Risk of hand injury. Safety gloves must be worn.	<b>WARNING!</b> Avoid direct eye contact
<b>DANGER!</b> Applies only to luminaires directly mounted on surfaces of non-combustible materials	<b>DANGER!</b> Do not discard Trash can	<b>DANGER!</b> Mark of ground	<b>DANGER!</b> Replace all shatter shields	<b>DANGER!</b> Take a short distance from the object to be photographed (meters)	<b>DANGER!</b> Rated maximum ambient temperature	<b>DANGER!</b> Do not point the lens towards the sun or strong light	<b>DANGER!</b> Operation not allowed during runtime

### Important:

**Damages caused by the disregard of this user manual are not subject to warranty. The dealer will not accept liability for any resulting defects or problems.**

- Unpack and check carefully to ensure that there is no transportation damage before using the unit.
- Do install and operate by qualified operator.
- The light source in this luminaire should be replaced by the manufacturer or its service agent or a similarly qualified person, always cut off the power supply before replacing the light source.
- Do not allow children to operate the fixture.
- Use safety chain when fixing the unit. Handle the unit by carrying its base instead of head only.
- The unit must be installed in a location with adequate ventilation, at least 50cm from adjacent surfaces.
- Be sure that no ventilation slots is blocked, otherwise the unit will be overheated.

- Before operation, ensure that you are connecting this product to the proper voltage in accordance with the specifications in this manual or on the product's specification label.
- It's important to ground the yellow/green conductor to earth in order to avoid electric shock.
- Minimum ambient temperature Ta: -20°C. Maximum ambient temperature Ta: 45°C.
- Do not operate this product at a lower or higher temperature.
- Do not connect the device to any dimmer pack.
- When the lamp is running, do not place combustible objects next to it. The shortest distance between the device and inflammable and explosive objects or materials is 1 m.
- Make sure the power cord is not crimped or damaged; replace it immediately if damaged.
- Unit's surface temperature may reach up to 65°C. Do not touch the housing bare-handed during its operation.
- Avoid any flammable liquids, water or metal from entering the unit. Once it happens, cut off the mains power immediately.
- Do not operate in a dirty or dusty environment. Do clean the fixture regularly.
- Do not touch any wire during operation as there might be a hazard of electric shock.
- Avoid entanglement of the power cord with other wires.
- The distance between the luminaire and the irradiated surface shall be greater than 3 meters.
- Do not shine light directly into another fixture's lens. Intense beam can damage internal components.
- Direct sunlight or any other strong light beam penetrating the front lens of the luminaire can cause severe internal damage. During unpacking, installation, operation, and extended idle periods outdoors, it is prohibited to expose the front lens of the luminaire to beams of direct sunlight or any other strong light source from any angle.

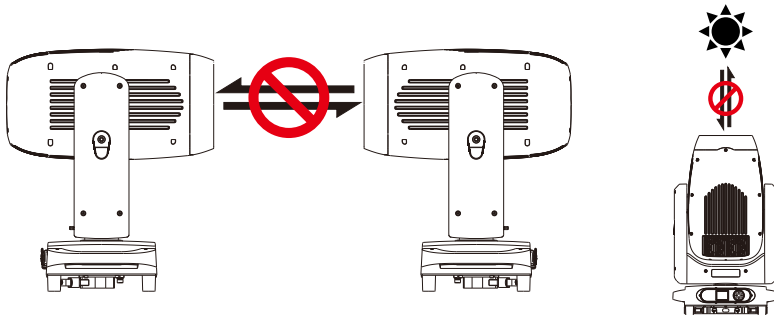

- In the event of serious operating problem, stop using the unit immediately.
- Never turn on and off the unit time after time.
- The housing, the lenses, or the ultraviolet filter must be replaced if they are visibly damaged.

- Do not open the housing as there are no user serviceable parts inside.
- Do not attempt to operate this unit if it becomes damaged. Do not attempt any repairs yourself. Repairs carried out by unskilled people can lead to damage or malfunction. Please contact the nearest authorized technical assistance center if needed.
- Disconnect this product from its power source before servicing.
- Do use the original packaging if the device is to be transported.
- Avoid direct eye exposure to the light source while the product is on.
- Do not operate this product if you see damage on the housing, shields, or cables. Have the damaged parts replaced by an authorized technician at once.

**Installation:**

The luminaire must be securely fastened to the quick-lock hook with screws to prevent vibration or slipping during operation. The supporting structure must be able to withstand 6 times the weight of the luminaire. Additionally, a safety cable must be installed that can endure 30 free-fall drops from 300mm without failure. Installation should only be performed by qualified professionals, and the luminaire must be mounted in an area inaccessible to unauthorized personnel or away from pedestrian traffic.

## 2. Technical Specifications

### OPTICS

- Light source: 520W white LED module
- Optical angle: 3.8 ° -50 °
- Optical lens: coated with high anti reflective film, Ø 146mm
- Color temperature: 7000 K
- Color rendering index: Ra ≥ 70 (cut in index ≥ 88)
- Illuminance: 34500 lx @10m
- Luminous flux: 24000 lm
- Average lifespan of light source: ≥ 50000h (The lifespan data above depends on several factors, including but not limited to: environmental factors, dimming control, power supply, voltage, switch cycling, usage mode, etc.)

### COLOR

- CMY infinite color mixing
- CTO Color Temperature Linear Adjustment (3000K-7000K)
- 6 color chips+white light+1 CRI, capable of achieving bidirectional color rainbow, dual color step gradient (linear movement), bidirectional rotation of color wheel, random color mode.

### PATTERN

- Rotating pattern disc: 7 types of glass patterns+white circles, can be plugged and replaced, can achieve rotation, flowing, and shaking effects.
- Fixed pattern plate: 7 types of glass patterns+white circles, which can achieve flowing and shaking effects.
- Effect disk: capable of achieving bidirectional flow and linear speed regulation effect
- Eight way cutting: 4 cutting blades achieve fast and smooth cutting, and the eight cutting directions and angles can be individually controlled. Each blade can achieve complete light closure, and the entire cutting module can rotate ± 90 °.

### EFFECT

- Prism: 4 rows of prisms+4 prisms, rotatable in both directions
- Soft light effect: light atomization+heavy atomization, adjustable independent soft light effect.
- Equipped with electric aperture, 5-100% linear adjustment, with macro functions and multi effect changes.
- Electronic dimming, 0-100% linear dimming, uniform light spot.
- The electronic strobe speed is 0.5-25 times/second.
- LED refresh rate: 1000Hz~25KHz

## **CONTROL AND PROGRAMMING**

- Control channel: 41CH/53CH/compatible channel 42CH, please refer to the channel table for details.
- Protocol: Standard DMX512 protocol, RDM protocol, ArtNet protocol, sACN protocol.
- Data connection: Three core or five core signal input/output, dual RJ45 interfaces.
- Display: LCD screen

## **SOFTWARE**

- Upgrade software through DMX interface
- Intelligent temperature control ensures LED lifespan
- Silent fan, three working modes (high brightness/standard/silent), (noise<40dB in silent mode)

## **X/Y AXIS MOTION ANGLE**

- X-axis: 540 ° (8-bit/16bit precision scanning)
- Y-axis: 270 ° (8-bit/16bit precision scanning)
- Reset function with automatic error correction
- Fixed lock: horizontal/vertical lock

## **POWER SUPPLY AND POWER**

- Input voltage: AC 100-240V 50/60Hz
- Maximum power: 847W
- Power factor: 0.99
- Maximum current of the lamp: 8.47A/100V; 3.8A/220V

## **DIMENSIONS & WEIGHT**

- Product size: 397 × 272 × 676mm
- N.W.: 29.6 kg
- Carton packaging (Default): 515 × 360 × 800mm
- G.W.: 35.8kg (including folding light hook)
- Flycase Size (2 units): 870 × 550 × 920mm
- G.W.: 103.5 kg

## **OTHER**

- Protection level: Ip66
- Working environment: -20 °C~45 °C
- Maximum surface temperature of lamp body: 65 °C
- Hook: Suitable for pipes with a diameter of 40-60 mm

## **APPROVALS**

- The product implementation standard: IEC 60598-1、IEC 60598-2-17
- Approved certifications: CE、RoHs
- The product complies with the following EU directives:  
Low Voltage Directive 2014/35/EU . EMC Directive 2014/30/EU

## illumination diagram

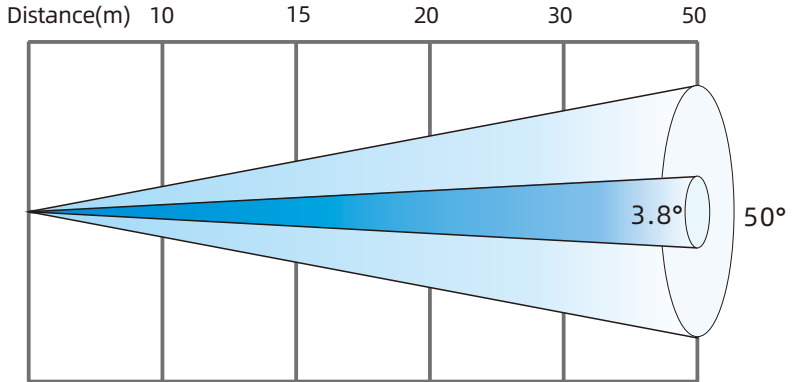

3.8° Lux	34500	15333	8625	3833	1380
Diameter(m)	0.66	0.99	1.32	1.98	3.3
50° Lux	504	224	126	56	20
Diameter(m)	9.34	14.01	18.68	28.02	46.7

## 2.1.Attachment And Size

Attachment contents-Fig.1

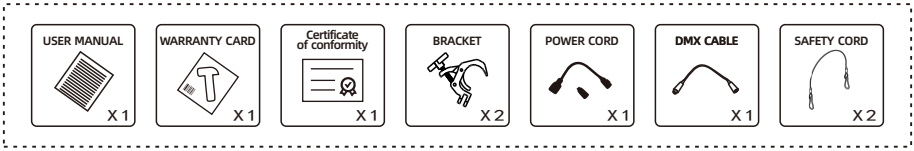

Size-Fig.2(Unit:mm)

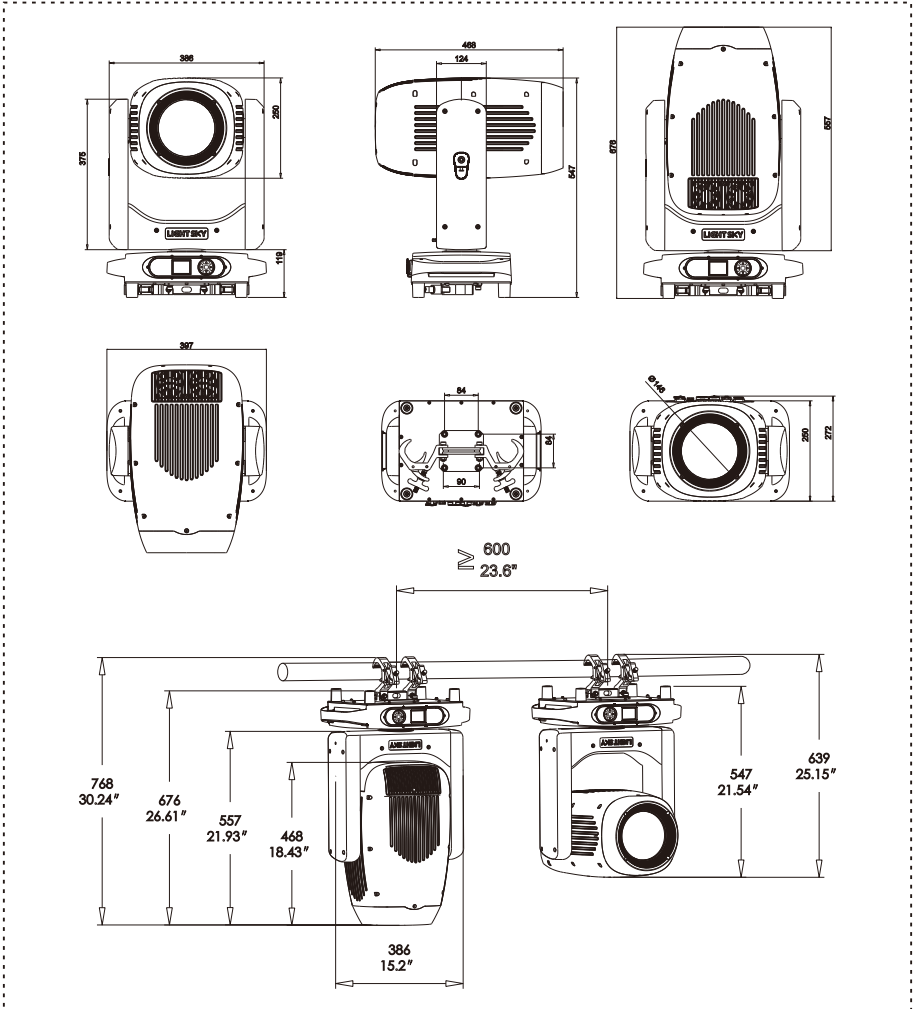

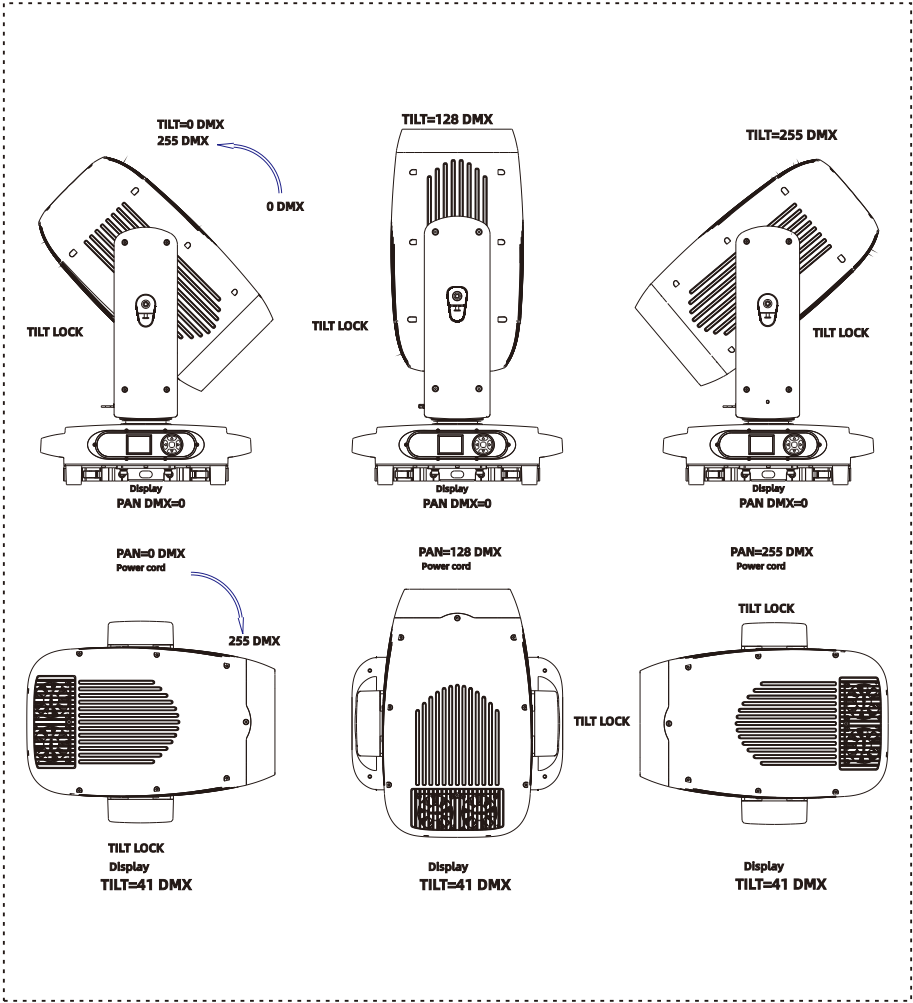

### 3.Color/Gobo/Prism

#### CMY-color wheel



CMY+CTO

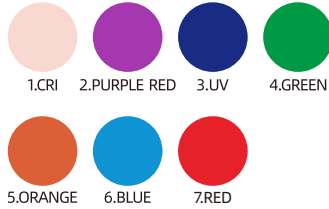

1.CRI 2.PURPLE RED 3.UV 4.GREEN

5.ORANGE 6.BLUE 7.RED

Color

#### Pattern

White

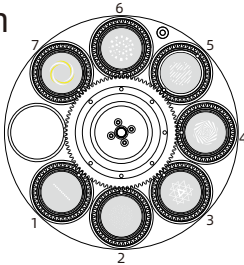

#### Glass pattern

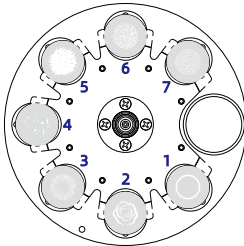
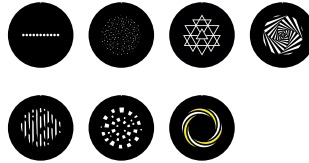

White

#### Metal pattern

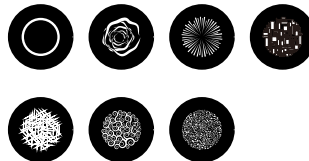

**DANGER!** Attention: When installing GOBO chips, it is necessary to strictly follow the order of the pictures and not change the original order and direction of the GOBO chips at will. Please disconnect the power supply when installing/replacing the rotating pattern piece!

#### Prism

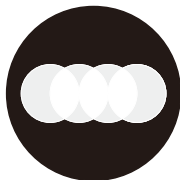

4 Prism

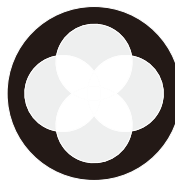

4 Prism

## 4.Control Panel

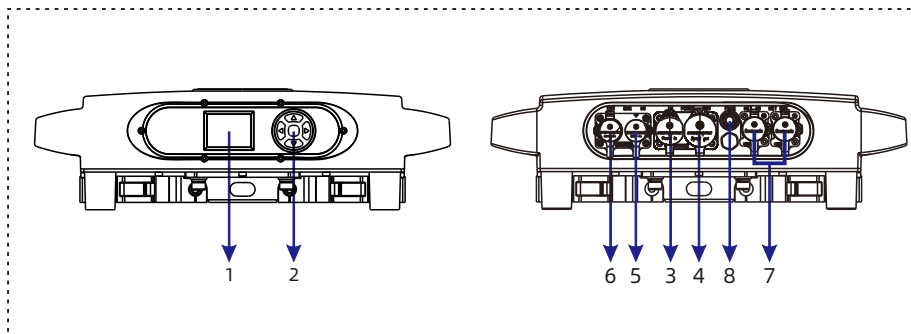

1.Display: To show the various menus and the selected function.

2.Button:

●	OK confirmation key
▲	UP
▼	DOWN
◀	To the left
▶	To the right

3.Power input: Connect the power supply.

4.Power output: Connect the lamp power output adapter.

5.DMX input: Used for DMX512 connection, use 3 core or 5 core XLR signal cable to connect console and lamps, And input DMX signal.

6.DMX output: Used for DMX512 connection, use 3 core or 5 core XLR signal cable to connect console and lamps, And output DMX signal.

7.Art-net/USB: The information of the lamp can be transmitted to the main controller through the network cable, and the lamp can be controlled through RJ45. USB optional.

8.Fuse holder: Used for the bottom box battery pack power supply display board when not powered on.(Note: In the case of air transportation, the lighting fixtures will require disassembly of fuses for shipment, and they must be installed by themselves upon receipt.)

## 5.Connection and control

### 5.1.Power supply connection

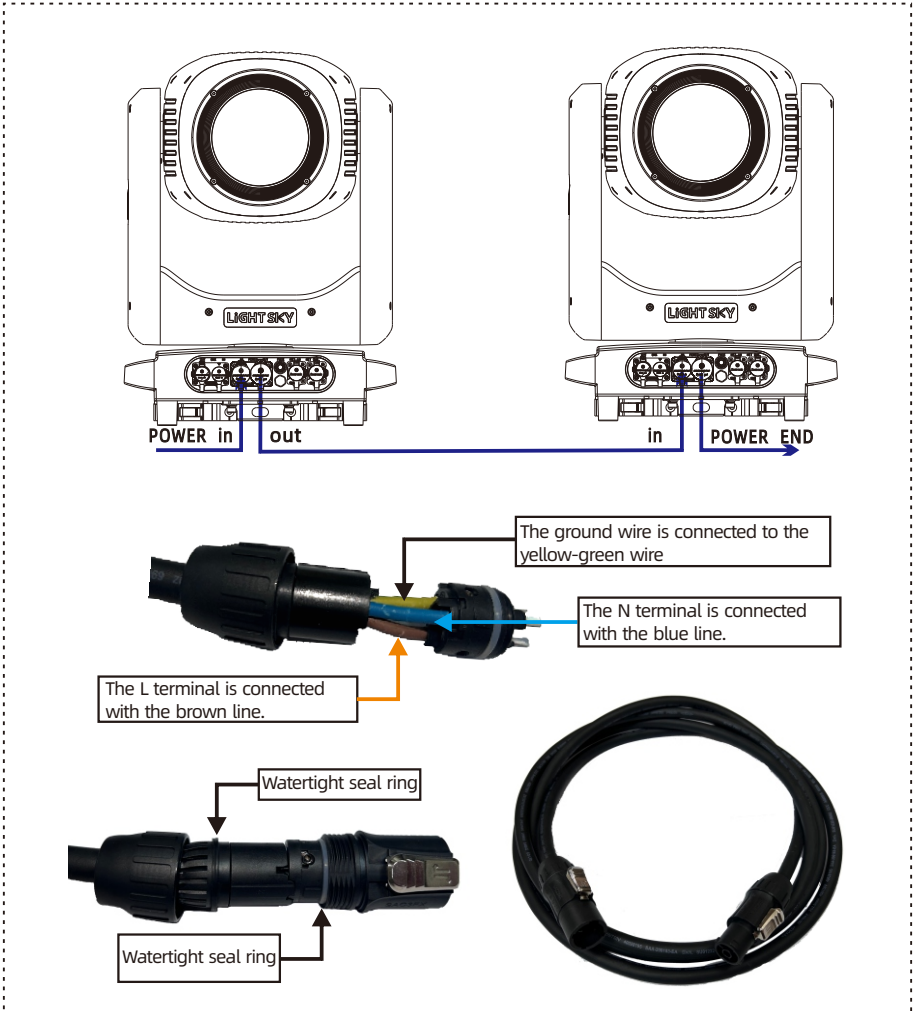

- The bus connecting the power supply must be installed by a qualified professional technician.
- After completing all the above operations and ensuring that it is installed, you can power on the lamp to operate.

## 5.2.DMX 512 Connection

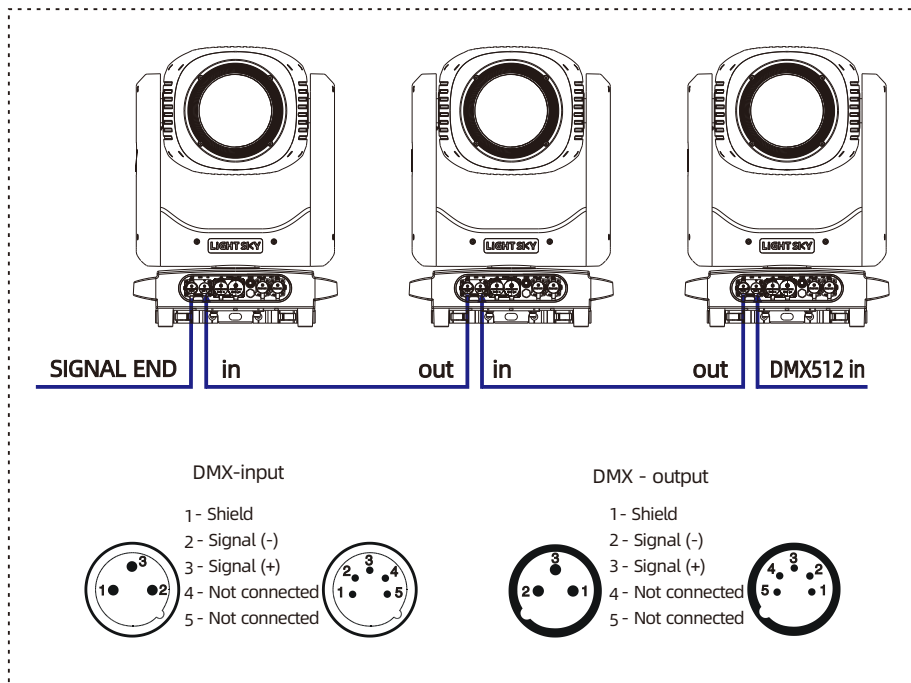

1. At last unit, the DMX cable has to be terminated with a terminator. Solder a 120  $\Omega$  1/4W resistor between pin 2(DMX-) and pin 3(DMX+) into a 3-pin XLR-plug and plug it in the DMX-output of the last unit.

2. Connect the unit together in a "daisy chain" by XLR plug cable from the output of the unit to the input of the next unit. The cable cannot be branched or split to a "Y" cable. DMX 512 is a very high-speed signal. Inadequate or damaged cables, soldered joints or corroded connectors can easily distort the signal and shut down the system.

3. The DMX output and input connectors are pass-through to maintain the DMX circuit, when one of the units' power is disconnected.

4. Each lighting unit needs to have a DMX address to receive the data by the controller. The address number is between 1-512.

5. The end of the DMX 512 system should be terminated to reduce signal errors.

6. 3 pin XLR connectors are more popular than 5 pins XLR.

3 pin XLR: Pin 1: GND, Pin 2: Negative signal (-), Pin 3: Positive signal (+)

5 pin XLR: Pin 1: GND, Pin 2: Negative signal (-), Pin 3: Positive signal (+), Pin4, Pin5 not used.

## 6.How To Set The Unit

### 6.1.Main Function

Main menu	I menu	II menu	III menu
Dmx Setting	1.Address	001-512	
	2.Channel	41CH	
		53CH	
	3.State	Compatible	
		Black	
	4.InputMode	Hold	
DMX			
5.DMX Address Lock	ARTNET	(ARTNET/SACN can only be selected when there is a network module)	
	SACN		
Information	1.Time	OFF	
		ON (Default)	
		Total Power Time ***H	
		Power Time ***H	
	2.Temperature	Total Light Time ***H	
		Light time ***H	
	3.Fan Information	LED Temp **°C	
		LedFanVol1 ***V	
		LedFanVol2 ***V	
		LedFan1Sp ***R	
		LedFan2Sp ***R	
		LedFan3Sp ***R	
		LedFan4Sp ***R	
		LedFan5Sp ***R	
		CMYFanVol ***V	
		CMYFanSp ***R	
		GoboFanVol ***V	
		GoboFanSp ***R	
		FocusFanVol1 ***V	
		FocusFanVol2 ***V	
		FocusFan1Sp ***R	
		FocusFan2Sp ***R	
		FocusFan3Sp ***R	
		BaseFanVol ***V	
		BaseFan1Sp ***R	
		BaseFan2Sp ***R	
	4.Information	MCU(XY) ***	
		MCU(CMY) ***	
		MCU(GOBO) ***	
		MCU(BLADE) ***	
		MCU(ZOOM) ***	
		MCU(FAN) ***	
		Pan ***	
		Tilt ***	
		Cyan ***	
		Magenta ***	
		Yellow ***	
Cto ***			
Color ***			
Gobo1 ***			
Gobo1 Rot. ***			

Main menu	I menu	II menu	III menu
	4.Fixture Status	Gobo2 ***	
		Fram Rot. ***	
		Zoom ***	
		Focus ***	
		Prism1 ***	
		Prism1 Rot. ***	
		LedFan1 ***	
		LedFan2 ***	
		LedFan3 ***	
		LedFan4 ***	
		LedFan5 ***	
		CMYFan ***	
		GoboFan ***	
		FocusFan1 ***	
	FocusFan2 ***		
	FocusFan3 ***		
	BaseFan1 ***		
	BaseFan2 ***		
	5.RDM UID	3888:*****	
	6.DMX Live	1.Pan ***	
		2.PanFine ***	
		3.....	
	7.Software	1.Display Ver. Vxxx	
		2.XY Ver. Vxxx	
		3.CMY Ver. Vxxx	
		4.Gobo Ver. Vxxx	
		5.Blade Ver. Vxxx	
6.Zoom Ver. Vxxx			
7.FAN Ver. Vxxx			
8.ETH Ver. Vxxx		(The network version will only be displayed when there is a network module)	
Personality	1.Dimmer&Fan Setting	1.Dimmer Curve	Linear
			Square (Default)
			I-Square
			S-Curve
		2.Dimmer Freq	1000HZ
			3600HZ
			7200HZ
		3.Dimmer Speed	25000HZ(Default)
			Normal (Default)
			Smooth 1
	4.Fan Mode	Smooth 2	
		Smooth 3	
		High Output	
2.PanTilt Setting	1.Pan Invert	Standard (Default)	
	2.Tilt Invert	Silent	
	3.P/T Rectify	OFF/ON	
		OFF/ON	
		OFF/ON	

Main menu	I menu	II menu	III menu		
		4.P/T Mode	Normal(Default)		
			Fast		
			Precise		
	3.Display Setting	1.Language 2.Dis.Backlight. 3.Dis.Direction 4.Dis.Blink		EN(Default) / ZH	
				OFF (Default) /ON	
				Forward (Default) Reverse	
				OFF/ON (Default)	
	4.Other Setting	1.Zoom Invert 2.CMY Mode 3.Gobo Rot. Way 4.FX Auto Focus		OFF(Default)/ON	
				Standard (Default) /Fast	
				Way1 (Default) /Way2	
				OFF/ON (Default)	
	5.Ethernet Setting (This menu can only be displayed when connected to a network module)	IP Address Mask Address Universe Address sACN Universe Address DHCP Ethernet To DMX		*** **.* **.* **.*	
				*** **.* **.* **.*	
0-32767					
1-63999					
OFF (Default) /ON					
OFF (Default) /ON					
Manual	1.Channel	1.Pan *** 2.Pan Fine *** 3.....			
			2.Reset	1.Total reset 2.Pan/Tilt reset 3.Gobo reset 4.Color reset 5.Profile reset 6.Focus reset 7.Effect reset	
	Service	1.Calibrate		1.Pan ***	
				2.Tilt ***	
3.Cyan ***					
4.Magenta ***					
5.Yellow ***					
6.Ct0 ***					
7.ColorWheel ***					
8.Gobo1 ***					
9.Gobo1 Rot.***					
10.Gobo2 ***					
11.Blade 1A ***					
12.Blade 1B ***					
13.Blade 2A ***					
14.Blade 2B ***					
15.Blade 3A ***					
16.Blade 3B ***					
17.Blade 4A ***					
18.Blade 4B ***					
19.FramingRot ***					
20.Prism1 ***					
21.Prism1 Rot***					
22.Prism2 ***					
23.Prism2 Rot ***					
24.Effect ***					

Main menu	I menu	II menu	III menu
		25.Frost1 ***	
		26.Frost2 ***	
		27.Iris ***	
		28.Zoom ***	
		29.Focus ***	
		30.Dimmer ***	
		31.FosForGo1 ***	
		32.FosForGo2 ***	
		33.FosForIris ***	
		34.FosForEffect ***	
	2.Factory Reset	Password : 1111	NO/ YES
	3.Reset timers		
	4.Developer		
	5.Firmware update		
Language	EN		
	ZH		
Test	1.Test PanTilt	Running:Step ***/**	
	2.Test Head Module	Running:Step ***/**	
	3.Test All	Running:Step ***/**	
Display Rotate	Normal		
	Rotate 180		

## 6.2.Address Setting

Enter MENU, select the DMA setting function, select the address code setting, press the OK button to confirm, and the current DMA address will be displayed in the On screen display. Use the up/down buttons to select addresses 001-512, press the OK button to save the current address code, and return to the previous menu level.

Please refer to the following diagram to address your DMX512 channel for the first 4 units.

<b>Channel mode</b>	<b>Unit 1 Address</b>	<b>Unit 2 Address</b>	<b>Unit 3 Address</b>	<b>Unit 4 Address</b>
53 Channel	1	54	107	160
41 Channel	1	42	83	124
Compatible(42)	1	43	85	127

## 6.3.DMX 512 Configuration

Please control the fixture by referring to the configurations below

53 Channel	41 Channel	DMX VALUE	FUNCTION	Note
1	1	0-255	<b>Pan</b> Pan movement/positioning	Angle:0-540° Maximal Speed:3.005
2	2	0-255	<b>Pan fine</b> Fine Pan movement/positioning	
3	3	0-255	<b>TILT</b> Tilt movement/positioning	Angle:0-270° Maximal Speed:1.905
4	4	0-255	<b>TILT fine</b> Fine Tilt movement/positioning	
5	5	0-255	<b>PAN TILT Speed</b> Pan Tilt movement Speed From Fast To Slow	
6	6	0 - 10 11 -- 20 21 -- 30 31 -- 40 41 -- 50 51 -- 60 61 -- 70 71 -- 80 81 -- 90 91 -- 100 101 -- 110 111 -- 115 116 -- 120 121 -- 125 126 -- 130 131 -- 135 136 -- 140 141 -- 145 146 -- 150 151 -- 155 156 -- 160 161 -- 165 166 -- 170 171 -- 175 176 -- 180 181 -- 185 186 -- 190 191 -- 200 201-- 205 206 --210 211-- 215 216 -- 220 221 -- 225 226 -- 230 231 -- 235 236 -- 240 241 -- 245 246 -- 250 251 -- 255	<b>Functions</b> No function All Reset XY Reset Color System Reset Gobo System Reset Profile System Reset Focus System Reset Noise mode:Silent Noise mode:Standard(Default) Noise mode:High Output Effect Reset LED frequency:1000HZ LED frequency:3600HZ LED frequency:7200HZ LED frequency:25000HZ(Default) Dimmer Curve:Linear Dimmer Curve:Square(Default) Dimmer Curve:I-Square Dimmer Curve:S-Curve Zoom Invert Zoom Forward (Default) Dmx state black(Default) Dmx state hold Display Back light is Always Display Back light is Auto(Default) CMY Mode:Standard(Default) CMY Mode:Fast Function Open Pan/Tilt Mode Standard(Default) Pan/Tilt Mode Fast Pan/Tilt Mode Precise Dimmer Speed:Normal(Default) Dimmer Speed:Smooth 1 Dimmer Speed:Smooth 2 Dimmer Speed:Smooth 3 Gobo Rotation Way1(Default) Gobo Rotation Way2 FX Auto Focus on FX Auto Focus off	

53 Channel	41 Channel	DMX VALUE	FUNCTION	Note
7	7	0--255	<b>Cyan</b> White→full cyan	
8	/	0--255	<b>Cyan Fine</b> Cyan Fine movement/positioning	
9	8	0--255	<b>Magenta</b> White → full magenta	
10	/	0--255	<b>Magenta Fine</b> Magenta Fine movement/positioning	
11	9	0--255	<b>Yellow</b> White→ full yellow	
12	/	0--255	<b>Yellow Fine</b> Yellow Fine movement/positioning	
13	10	0--255	<b>CTO</b> Color Temperature from Deep to mall	
14	/	0--255	<b>CTO Fine</b> CTO Fine movement/positioning	
15	11	0 - 89 90 - 100 101 - 111 112 - 122 123 - 133 134 - 144 145 - 155 156 - 166 167 - 179 180 - 214 215 - 249 250 - 255	<b>Colour wheel</b> 0 - 360° OPEN COLOR1 COLOR2 COLOR3 COLOR4 COLOR5 COLOR6 COLOR7 Forwards Color rotation from fast to slow Backwards Color rotation from slow to fast Random Color	Angle: 0-360°  Speed: 74->0 RPM Speed: 0->74 RPM
16	12	0 - 9 10-19 20 - 29 30 - 39 40 - 49 50 - 59 60 - 69 70-79 80-87 88-95 96-103 104-111 112-119 120-127 128-135 136-139 140 - 194 195 - 249 250 - 255	<b>Gobo</b> Open GOBO1 GOBO2 GOBO3 GOBO4 GOBO5 GOBO6 GOBO7 Gobo 1 shake slow to fast Gobo 2 shake slow to fast Gobo 3 shake slow to fast Gobo 4 shake slow to fast Gobo 5 shake slow to fast Gobo 6 shake slow to fast Gobo 7 shake slow to fast Open Forwards gobo rotation from fast to slow Backwards gobo rotation from slow to fast Random Gobo	Speed: 0.2->6.25 HZ Speed: 0.2->6.25 HZ Speed: 0.2->6.25 HZ Speed: 0.2->6.25 HZ Speed: 0.2->6.25 HZ Speed: 0.2->6.25 HZ Speed: 0.2->6.25 HZ Speed: 74->0 RPM Speed: 0->74 RPM

53 Channel	41 Channel	DMX VALUE	FUNCTION	Note
17	13		<b>Gobo Rotation (Way1 Default)</b>	
		0	0°	
		1- 2	Gobo rotation stop	
		3-63	Forwards gobo rotation from fast to slow	Speed : 94->0 RPM
		64	Gobo rotation stop	
		65-192	Angle:-180° - 180°	Default 128 is 0°
		193	Gobo rotation stop	
		194-254	Backwards gobo rotation from slow to fast	Speed: 0->94 RPM
		255	Gobo rotation stop	
			<b>Gobo Rotation (Way2)</b>	
		0-127	Gobo indexing 0-360°	Angle: 0-360°
		128-189	Forwards gobo rotation from fast to slow	Speed : 94->0 RPM
		190-193	No rotation	
194-255	Backwards gobo rotation from slow to fast	Speed : 0->94 RPM		
18	14		<b>Gobo2</b>	
		0 - 9	Open	
		10-19	GOBO1	
		20 - 29	GOBO2	
		30 - 39	GOBO3	
		40 - 49	GOBO4	
		50 - 59	GOBO5	
		60 - 69	GOBO6	
		70-79	GOBO7	
		80-87	Gobo 1 shake slow to fast	Speed : 0.2->6.25 HZ
		88-95	Gobo 2 shake slow to fast	Speed : 0.2->6.25 HZ
		96-103	Gobo 3 shake slow to fast	Speed : 0.2->6.25 HZ
		104-111	Gobo 4 shake slow to fast	Speed : 0.2->6.25 HZ
		112-119	Gobo 5 shake slow to fast	Speed : 0.2->6.25 HZ
		120-127	Gobo 6 shake slow to fast	Speed : 0.2->6.25 HZ
		128-135	Gobo 7 shake slow to fast	Speed : 0.2->6.25 HZ
		136-139	Open	
		140 - 194	Forwards gobo rotation from fast to slow	Speed : 74->0 RPM
		195 - 249	Backwards gobo rotation from slow to fast	Speed : 0->74 RPM
		250 - 255	Random Gobo	
19	15	0 - 255	<b>Blade1A</b> Blade Out→In	
20	/	0 - 255	<b>Blade1A Fine</b> Fine Blade positioning	
21	16	0 - 255	<b>Blade1B</b> Blade Out→In	
22	/	0 - 255	<b>Blade1B Fine</b> Fine Blade positioning	
23	17	0 - 255	<b>Blade2A</b> Blade Out→In	
24	/	0 - 255	<b>Blade2A Fine</b> Fine Blade positioning	
25	18	0 - 255	<b>Blade2B</b> Blade Out→In	
26	/	0 - 255	<b>Blade2B Fine</b> Fine Blade positioning	
27	19	0 - 255	<b>Blade3A</b> Blade Out→In	

53 Channel	41 Channel	DMX VALUE	FUNCTION	Note
28	/	0 - 255	<b>Blade3A Fine</b> Fine Blade positioning	
29	20	0 - 255	<b>Blade3B</b> Blade Out→In	
30	/	0 - 255	<b>Blade3B Fine</b> Fine Blade positioning	
31	21	0 - 255	<b>Blade4A</b> Blade Out→In	
32	/	0 - 255	<b>Blade4A Fine</b> Fine Blade positioning	
33	22	0 - 255	<b>Blade4B</b> Blade Out→In	
34	/	0 - 255	<b>Blade4B Fine</b> Fine Blade positioning	
35	23	0 - 255	<b>Framing Rotation</b> 0° - 180°	Angle: 0-180°
36	24	0 -- 10 11 -- 20 21 -- 30 31 -- 40 41 -- 50 51 -- 60 61 -- 70 71 --80 81 --90 91 --100 101--110 111--120 121--130 131--140 141--150 151--160 161--170 171--180 181--190 191--200 201--255	<b>Framing Macro</b> No function Square rectangle Isosceles triangle trapezoidal The Fan(Facing Up) parallelogram Right Angle trapezoid The Fan(Down) triangle prismatic The stripes bar Upper left quadrant semicircle (Up) Upper right quadrant Right semicircle Right lower quadrant Semicircle (Down) The lower left quadrant Left Semicircle	
37	25	0 - 255	<b>Framing Macro Zoom</b> Framing Macro Zoom	
38	26	0 - 10 11-100 101-255	<b>Prism</b> Prism Out Prism 1 Prism 2	Angle: 0-77° Angle: 0-77°
39	27	0 1--63 64-127 128-191 192-207 208-223 224-239 240-255	<b>Prism Rotation</b> No Function 0--360°/Linear adjust Forwards rotation from fast to slow Backwards rotation from slow to fast from slow to fast 90°Swing from slow to fast 180°Swing from slow to fast 270°Swing from slow to fast 360°Swing	Angle: 0-360° Speed: 32->0 RPM Speed: 0->32 RPM 0.02->0.7 HZ 0.02->0.7 HZ 0.02->0.7 HZ

53 Channel	41 Channel	DMX VALUE	FUNCTION	Note
40	28	0 - 9 10 - 255	<b>Effect</b> Effect Out Effect In	
41	29	0 - 2 3 - 130 131 - 255	<b>Effect Rotation</b> No Function Forwards rotation from fast to slow Backwards rotation from fast to slow	Speed: 6.25->0 RPM Speed: 0->6.25 RPM
42	30	0 - 10 11-100 101 - 255	<b>Frost</b> Frost Out Frost1 Linear 0-100% Frost2 Linear 0-100%	Angle: 0-30° Angle: 0-30°
43	31	0 - 127 128 - 159 160 - 191 192 - 255	<b>Iris</b> From Max To Min Slow In Fast Out from slow to fast Fast In Slow Out from slow to fast Slow In Slow Out from slow to fast	Angle: 0-270° 0.1->5 HZ 0.1->5 HZ 0.1->5 HZ
44	32	0 - 255	<b>Zoom</b> WIDE BEAM->NARROW BEAM	
45	33	0 - 255	<b>ZoomFine</b> Fine Zoom positioning	
46	34	0 - 255	<b>Focus</b> Infinity->near	
47	35	0 - 255	<b>Focus Fine</b> Fine Focus positioning	
48	36	0 - 9 10 -- 19 20 -- 29 30 -- 39 40 -- 49 50 -- 59 60 - 69 70 - 79 80 -- 255	<b>Autofocus Distance</b> NO function 7M 10M 15M 20M 25M 30M 40M 50M	
49	37	0-255	<b>Autofocus Adjustment</b> Auto Focus Fine	
50	38	0-9 10-49 50-89 90-119 120 - 179 180-255	<b>Strobe</b> No Function Closing pulses in sequences from fast to slow Opening pulses in sequences from fast to slow No Function Random strobe,slow → fast Strobe,slow → fast	25->0.5 HZ 25->0.5 HZ 0.5->25 HZ 0.5->25 HZ
51	39	0 - 255	<b>Dimmer</b> Dimmer from Dark To Bright	
52	40	0 - 255	<b>Dimmer Fine</b> Dimmer Fine	
53	41	0-15 16-255	<b>Gobo Macro</b> No Function Gobo Macro Function	

42 Channel	DMX VALUE	FUNCTION	Note
1	0-255	<b>Pan</b> Pan movement/positioning	Angle: 0-540°, Maximal Speed: 3.00S
2	0-255	<b>Pan fine</b> Fine Pan movement/positioning	
3	0-255	<b>TILT</b> Tilt movement/positioning	Angle: 0-270°, Maximal Speed: 1.90S
4	0-255	<b>TILT fine</b> Fine Tilt movement/positioning	
5	0-255	<b>Pan Motor continuous rotation</b>	Compatible channel, currently without functionality
6	0-255	<b>Tilt Motor continuous rotation</b>	Compatible channel, currently without functionality
7	0-10 11-20 21-117 118-126 127-180 181-191 192-245 246-255	<b>Strobe</b> Strobe closed No function (Strobe open) Strobe effect slow to fast No function (Strobe open) Pulse-effect in sequences No function (Strobe open) Random strobe effect slow to fast No function (Strobe open)	0.5->25 HZ  0.5->25 HZ  0.5->25 HZ
8	0 - 255	<b>Dimmer</b> Dimmer from Dark To Bright	
9	0 - 255	<b>Dimmer Fine</b> Dimmer Fine	
10	0 - 255	<b>Zoom</b> WIDE BEAM→NARROW BEAM	
11	0 - 255	<b>ZoomFine</b> Fine Zoom positioning	
12	0 - 255	<b>Focus</b> Infinity→near	
13	0 - 255	<b>Focus Fine</b> Fine Focus positioning	
14	0-3 4-7 8-11 12-15 16-19 20-23 24-27 28-31 32-127 128-189 190-193 194-255	<b>Colour wheel</b> Open /white COLOR1 COLOR2 COLOR3 COLOR4 COLOR5 COLOR6 COLOR7 Color index 0-360° Forwards Color rotation from fast to slow No rotation Backwards Color rotation from slow to fast	Angle: 0-360° Speed: 74->0 RPM  Speed: 0->74 RPM

42 Channel	DMX VALUE	FUNCTION	Note
15	0-255	<b>Colour wheel Fine</b> Color Wheel colour change to any position Fine	
16	0--255	<b>Cyan</b> White→full cyan	
17	0--255	<b>Magenta</b> White → full magenta	
18	0--255	<b>Yellow</b> White→ full yellow	
19	0--255	<b>CTO</b> Color Temperature from Deep to mall	
20	0-255	<b>CTP</b>	Compatible channel, currently without functionality
21	0 - 9 10-19 20 - 29 30 - 39 40 - 49 50 - 59 60 - 69 70-77 78-93 94-109 110-125 126-141 142-157 158-173 174-189 190-221 222-223 224-255	<b>Gobo</b> Open GOBO1 GOBO2 GOBO3 GOBO4 GOBO5 GOBO6 GOBO7 Gobo 1 shake slow to fast Gobo 2 shake slow to fast Gobo 3 shake slow to fast Gobo 4 shake slow to fast Gobo 5 shake slow to fast Gobo 6 shake slow to fast Gobo 7 shake slow to fast Forwards gobo rotation from fast to slow No rotation Backwards gobo rotation from slow to fast	Speed: 0.2->6.25 HZ Speed: 0.2->6.25 HZ Speed: 0.2->6.25 HZ Speed: 0.2->6.25 HZ Speed: 0.2->6.25 HZ Speed: 0.2->6.25 HZ Speed: 0.2->6.25 HZ Speed: 74->0 RPM Speed: 0->74 RPM
22	0-127 128-189 190-193 194-255	<b>Gobo Rotation</b> Gobo indexing 0-360° Forwards gobo rotation from fast to slow No rotation Backwards gobo rotation from slow to fast	Angle: 0-360° Speed: 94->0 RPM Speed: 0->94 RPM
23	0-255	<b>Gobo Rotation Fine</b> Fine indexing	
	0 - 9 10-19 20 - 29 30 - 39 40 - 49 50 - 59 60 - 69	<b>Gobo2</b> Open GOBO1 GOBO2 GOBO3 GOBO4 GOBO5 GOBO6	

42 Channel	DMX VALUE	FUNCTION	Note
24	70-79	GOGO7	Compatible channel, currently without functionality
	80-89	GOGO8	
	90-99	GOGO9	Compatible channel, currently without functionality
	100-109	Gobo 1 shake slow to fast	Speed: 0.2->6.25 HZ
	110-119	Gobo 2 shake slow to fast	Speed: 0.2->6.25 HZ
	120-129	Gobo 3 shake slow to fast	Speed: 0.2->6.25 HZ
	130-139	Gobo 4 shake slow to fast	Speed: 0.2->6.25 HZ
	140-149	Gobo 5 shake slow to fast	Speed: 0.2->6.25 HZ
	150-159	Gobo 6 shake slow to fast	Speed: 0.2->6.25 HZ
	160-169	Gobo 7 shake slow to fast	Speed: 0.2->6.25 HZ
	170-179	Gobo 8 shake slow to fast	Compatible channel, currently without functionality
	180-189	Gobo 9 shake slow to fast	Compatible channel, currently without functionality
	190-221	Forwards gobo rotation from fast to slow	Speed: 74->0 RPM
	222-223	No rotation	
224-255	Backwards gobo rotation from slow to fast	Speed: 0->74 RPM	
25	0 - 7	<b>Effect</b> Effect out	Speed: 6.25->0 RPM
	8-127	Forwards rotation from fast to slow	
	128-135	No rotation	Speed: 0->6.25 RPM
	136-255	Backwards rotation from slow to fast	
26	0 - 191	<b>Iris</b> From Max To Min	Angle: 0-270°
	192-223	Slow In Fast Out from fast to slow	0.1->5 HZ
	224-255	Fast In Slow Out from slow to fast	0.1->5 HZ
27	0 - 127	<b>Prism</b> Prism Out	Angle: 0-77°
	128-255	Prism 1	
28	0-127	<b>Prism Rotation</b> Prism indexing 0--360°	Angle: 0-360°
	128-189	Forwards rotation from fast to slow	Speed: 32->0 RPM
	190-193	No rotation	
	194-255	Backwards rotation from slow to fast	Speed: 0->32 RPM
29	0-127	<b>Prism2</b> Prism Out	Angle: 0-77°
	128-255	Prism 2	
30	0-127	<b>Prism Rotation2</b> Prism indexing 0--360°	Angle: 0-360°
	128-189	Forwards rotation from fast to slow	Speed: 32->0 RPM
	190-193	No rotation	Speed: 0->32 RPM
	194-255	Backwards rotation from slow to fast	0.02->0.7 HZ
31	0-255	<b>Frost1</b> Frost1 0-100%	Angle: 0-30°

42 Channel	DMX VALUE	FUNCTION	Note
32	0-255	<b>Frost2</b> Frost2 0-100%	Angle: 0-30°
33	0 - 255	<b>Blade1A</b> Blade Out→In	
34	0 - 255	<b>Blade1B</b> Blade Out→In	
35	0 - 255	<b>Blade2A</b> Blade Out→In	
36	0 - 255	<b>Blade2B</b> Blade Out→In	
37	0 - 255	<b>Blade3A</b> Blade Out→In	
38	0 - 255	<b>Blade3B</b> Blade Out→In	
39	0 - 255	<b>Blade4A</b> Blade Out→In	
40	0 - 255	<b>Blade4B</b> Blade Out→In	
41	0 - 255	<b>Framing Rotation</b> 0° - 180°	Angle: 0-180°
		<b>Functions</b> 0-4 No function 5-9 Display Off 10-14 Display On 15-19 Display Invert Off 20-24 Display Invert On 25-26 Noise mode:Standard 27-28 Noise mode:High Output 29-30 Noise mode:Silent 31-32 Reserved 33-34 Reserved 35-36 Reserved 37-39 Dimmer Curve:S-Curve 40-44 Dimmer Curve:I-Square 45-49 Dimmer Curve:Square(Default) 50-54 Dimmer Curve:Linear 55-58 LED frequency:1000HZ 59-62 LED frequency:3600HZ 63-66 LED frequency:7200HZ 67-69 LED frequency:25000HZ(Default) 70-74 Reserved 75-79 Reserved 80-84 All motor reset 85-87 Scan motor reset 88-90 Colours motor reset 91-93 Gobo motor reset 94 Reserved	

42 Channel	DMX VALUE	FUNCTION	Note
42	95	Reserved	
	96	Reserved	
	97-99	Other motor reset	
	100-102	Reserved	
	103-105	Reserved	
	106-108	CMY Mode:Standard	
	109-111	CMY Mode:Theater	
	112-114	Reserved	
	115-117	Zoom Invert	
	118-120	Zoom Forward (Default)	
	121-123	Reserved	
	124-126	Reserved	
	127-129	Pan Invert Off	
	130-132	Pan Invert On	
	133-135	Tilt Invert Off	
	136-138	Tilt Invert On	
	139-141	Reserved	
	142-144	Reserved	
	145-147	Reserved	
	148-150	Reserved	
	151-153	Reserved	
	154-156	Reserved	
	157-159	Reserved	
	160-162	Reserved	
	163-165	Reserved	
	166-168	Reserved	
	169-171	Reserved	
	172-174	Reserved	
	175-177	Reserved	
	178-180	Reserved	
	181-183	Pan/Tilt Spd Fast	
	184-186	Pan/Tilt Spd Medium	
187-189	Pan/Tilt Spd Slow		
190-192	Reserved		
193-195	Reserved		
196-198	Reserved		
199-201	Reserved		
202-204	Reserved		
205-207	Reserved		
208-210	Reserved		
211-213	Reserved		
214-216	Reserved		
217-219	Reserved		
220-222	Reserved		
223-225	Reserved		
226-228	Reserved		
229-231	Reserved		
232-255	Reserved		

## 7. Electrical Connection Diagram

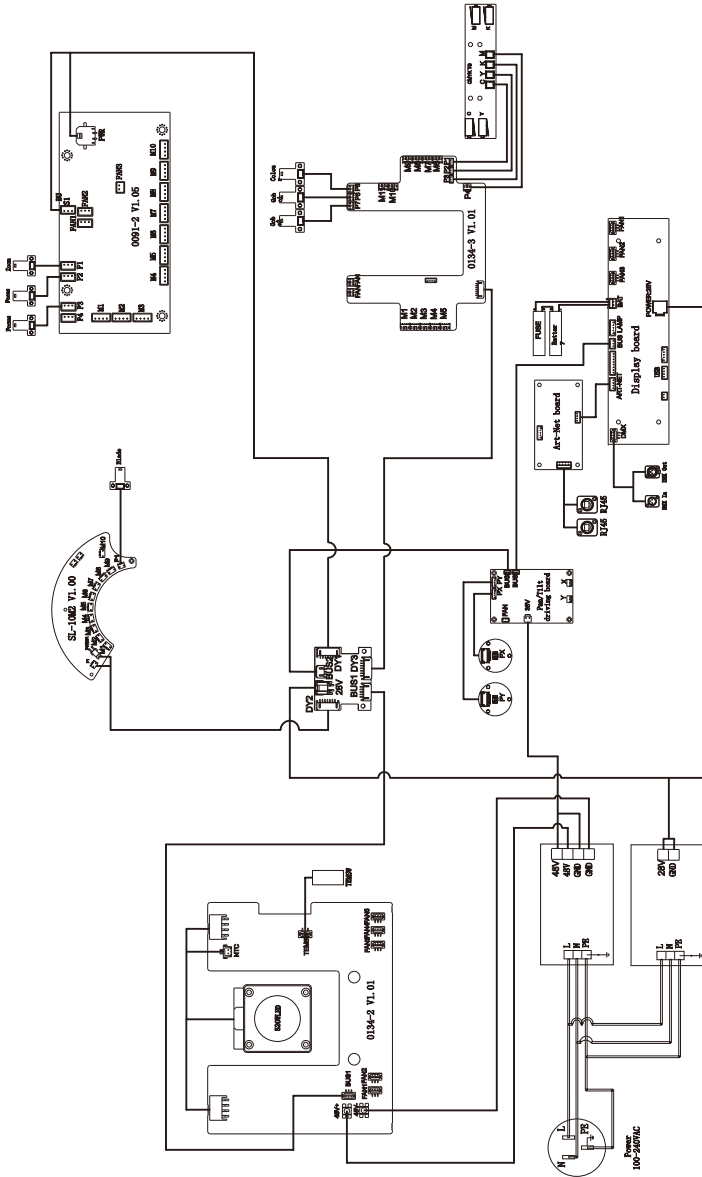

## 8. Troubleshooting

The following are common faults of lamps and corresponding solutions. Faults that cannot be repaired by yourself should be handled by professionally qualified personnel. Disconnect the power supply to the lamp during maintenance!

- The light source is not bright
  - Check that a suitable light source is installed for the luminaire.
  - Check whether the power supply connection of the lamp or the control switch is in poor contact.
  - Check whether the light source has reached the end of its service life or is damaged, and replace it with a high-quality light source of the same specification.
  - Measure whether the power supply is insufficient.
  - Check whether the over-temperature protection temperature switch inside the lamp is damaged. Go to the menu "Basic Information" and select "Equipment Temperature" to check - whether the temperature measuring plate shows that the temperature is too high or there is no temperature display.
- The beam appears dim and uneven
  - The light source may have reached the end of its service life and does not emit enough light. Replace it with a light source of the same specification.
  - Check whether there is dust accumulated in the optical part and clean it.
  - Measure whether the power supply is insufficient.
  - Enter the menu "Service Options" and select "Calibration" to enter color and pattern adjustment, which can be adjusted to the center.
- The projected image is blurry
  - Check whether the DMX512 controller channel value corresponding to the electronic focus system is suitable for the current projection distance.
  - Check whether the mechanical part of the focusing system is stuck, remove the dust and add antifreeze and temperature-resistant lubricating oil.
- The light source of the lamp works intermittently
  - Check whether the fan is running normally or is blocked by dust and paper debris.
  - Check whether the inlet and outlet cooling air vents are blocked by dust.
  - Check whether the lamp has reached the end of its service life.
  - Check whether the power supply is insufficient, and whether the power switch and wiring are in poor contact or aging.
  - Check whether the over-temperature protection temperature switch inside the lamp is damaged.
- Although it emits light, the lamp does not accept instructions from the controller
  - Check whether the digital start address value and function options of the lamp are correct.
  - Check whether the connection of the communication control line is correct. The communication line is too long or has been interrupted.

- Check whether the control equipment fails and whether the signal amplifier connected in series fails.
- Check whether the communication line is too long or if other devices interfere with each other.
- Optimize wiring, shorten the length of control signal lines, and route high-voltage and low-voltage lines separately.
- Add signal amplifier isolator.
- The signal line is made of high-quality shielded twisted pair (impedance characteristic is  $75\Omega$ ), and the signal terminal resistor is connected at the end of the lamp.
- Check that the circuit board communication IC or CPU is burned out because the bulb performs an abnormal operation when it is not completely cooled, causing the instantaneous ultra-high voltage leakage generated by the trigger, and replace the PCB board.
- The lamp cannot be started
  - Check whether the power supply parameters match the lamps.
  - Check whether the fuse at the light fixture's power input is blown.
  - Check that the lamp has poor contact or falls off due to extrusion deformation, vibration of internal parts, moisture, etc. during long-distance transportation.
  - Check whether the internal wires and connectors of the lamp are desoldered or loose.
  - Check whether the electrical components of the lamp (such as power switch, transformer, ballast, capacitor, varistor, filter, power supply PCB board, motor control PCB board, etc.) are loose, short-circuited, burned out, etc.
- Some functions of the lamp cannot accept controller instructions
  - Check whether the control device sends correct action instructions for these functions.
  - Check whether the mechanical parts corresponding to these functions are loose or deformed.
  - Check whether the motor sockets corresponding to these functions are loose or the corresponding driver chips are burned out.
  - Check whether the motor wires corresponding to these functions are broken at the corners.
  - Check whether the motors corresponding to these functions are damaged.
- During operation, the x or Y direction of the lamp does not move normally
  - Click the previous step to check one by one.
  - Check whether the corresponding drive belts in the X and Y directions of the lamp are detached or broken.
  - Check whether the data feedback receiver corresponding to the X and Y directions in the lamp is damaged.
- Restart the computer and reset it once.

## 9. Fixture Cleaning

It is absolutely essential that the fixture is kept clean to ensure the maximum light-output and allow the fixture to function reliably throughout its life. The fixture must be cleaned regularly to avoid dust, dirt and smoke-fluid residues building up on or within the fixture. The cleaning frequency depends on the application environment. Clean the fixture immediately if the dust enters it to avoid damage to the optical lens due to excessive dust.

- A soft lint-free cloth moistened with any good glass cleaning fluid is recommended, under no circumstances should solvents be used.
- Always dry the parts carefully.
- Clean the external optical lens at least every 20 days .



**CAUTION ! ! !**

**Disconnect from mains before starting maintenance operation.**

## 10. Duty exonerative and copyright protectio

- The manufacturer shall not bear any responsibility for any damage caused by failure to operate in accordance with this instruction.
- The manufacturer reserves the right of final interpretation for all information in this manual. For any questions, please refer to the official website.
- All the information in this manual shall not be copied without permission.
- The data contained in this statement are subject to change in the future without prior notice.