

# LIGHT SKY

[www.lightsky.com.cn](http://www.lightsky.com.cn)

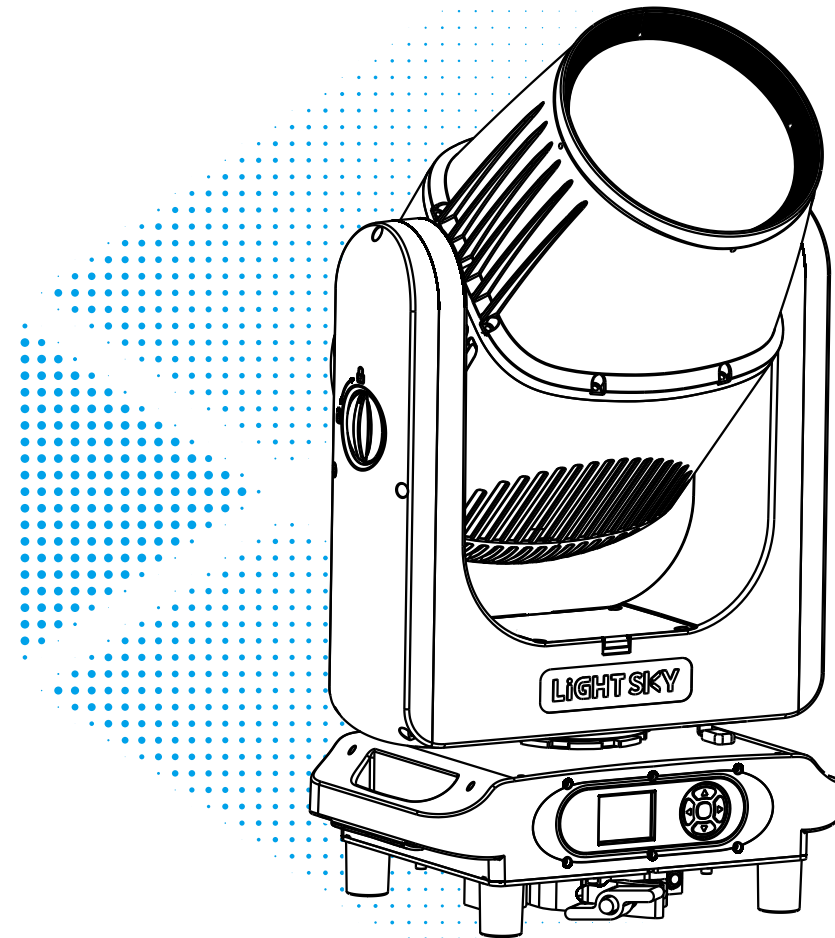

Fly Dragon Lighting Equipment Co., Ltd.

Add : NO.4 JINGNENG ROAD 1, HUADU DISTRICT, GUANGZHOU, CHINA.  
Tel : 020-61828288 Fax : 020-61828188 Postal Code : 510820  
Email : flydragon@lightsky.com.cn



Social Media



LIGHT SKY Wechat

## DOLPHIN SMART User Manual

Please read the instruction carefully before use

# CONTENTS

1. Safety Instructions .....	2
2. Technical Specifications .....	5
2.1. Attachment And Size .....	7
3. Color/Gobo/Prism .....	10
4. Control Panel.....	11
5. Connection and control.....	12
5.1. Power supply connection .....	12
5.2. DMX 512 Connection .....	13
6. How To Set The Unit .....	14
6.1. Main Function.....	14
6.2. Address Setting .....	17
6.3. DMX 512 Configuration .....	22
7. Electrical Connection Diagram .....	22
8. Troubleshooting .....	23
9. Fixture Cleaning .....	25
10. Duty exonerative and copyright protectio .....	25

## **Congratulations on choosing our company product! We thank you for your custom.**

- Please keep in mind that this product, like other products of the company, adheres to the concept of people-oriented design and manufacture, and takes product quality as the foundation.
- We put the interests of customers first, and do our best to meet customer requirements.
- Please read this instruction manual carefully and keep it for future reference. In the case of fully understanding the product information, strictly abide by theUse the instruction manual to ensure that the product is installed, used and serviced correctly and safely.
- Our company is not responsible for any damage to lamps or other performance due to personal failure to follow the instructions during installation, use and maintenance.responsibility.
- Our company reserves the right to modify the manual at any time and without prior notice.

## 1. Safety Instructions



**WARNING**

Please read the instruction carefully which includes important information about the installation, usage and maintenance.

Please keep this User Manual for future consultation. If you sell the unit to another user, be sure that they also receive this manual.

The following symbols are used to identify important safety information on the product and in this manual:

<b>WARNING!</b> Safety hazard. Risk of severe injury or death.	<b>WARNING!</b> Refer to manual before installing, powering or servicing.	<b>WARNING!</b> Hazardous voltage. Risk of severe or lethal electric shock.	<b>WARNING!</b> Fire hazard.	<b>WARNING!</b> Burn hazard. Hot surface, not touch. Do not touch	<b>WARNING!</b> Risk of eye injury. Safety glasses must be worn.	<b>WARNING!</b> Risk of hand injury. Safety gloves must be worn.	<b>WARNING!</b> Avoid direct eye contact
<b>DANGER!</b> Applies only to luminaires directly mounted on surfaces of non-combustible materials	<b>DANGER!</b> Do not discard Trash can	<b>DANGER!</b> Mark of ground	<b>DANGER!</b> Replace all shatter shields	<b>DANGER!</b> Take a short distance from the object to be photographed (meters)	<b>DANGER!</b> Rated maximum ambient temperature	<b>DANGER!</b> Do not point the lens towards the sun or strong light	<b>DANGER!</b> Operation not allowed during runtime

### Important:

**Damages caused by the disregard of this user manual are not subject to warranty. The dealer will not accept liability for any resulting defects or problems.**

- Unpack and check carefully to ensure that there is no transportation damage before using the unit.
- Do install and operate by qualified operator.
- The light source in this luminaire should be replaced by the manufacturer or its service agent or a similarly qualified person, always cut off the power supply before replacing the light source.
- Do not allow children to operate the fixture.
- Use safety chain when fixing the unit. Handle the unit by carrying its base instead of head only.
- The unit must be installed in a location with adequate ventilation, at least 50cm from adjacent surfaces.
- Be sure that no ventilation slots is blocked, otherwise the unit will be overheated.

- Before operation, ensure that you are connecting this product to the proper voltage in accordance with the specifications in this manual or on the product's specification label.
- It's important to ground the yellow/green conductor to earth in order to avoid electric shock.
- Minimum ambient temperature Ta: -20°C. Maximum ambient temperature Ta: 45°C.
- Do not operate this product at a lower or higher temperature.
- Do not connect the device to any dimmer pack.
- When the lamp is running, do not place combustible objects next to it. The shortest distance between the device and inflammable and explosive objects or materials is 1 m.
- Make sure the power cord is not crimped or damaged; replace it immediately if damaged.
- Unit's surface temperature may reach up to  $\leq 60^{\circ}\text{C}$ . Do not touch the housing bare-handed during its operation.
- Avoid any flammable liquids, water or metal from entering the unit. Once it happens, cut off the mains power immediately.
- Do not operate in a dirty or dusty environment. Do clean the fixture regularly.
- Do not touch any wire during operation as there might be a hazard of electric shock.
- Avoid entanglement of the power cord with other wires.
- The distance between the luminaire and the irradiated surface shall be greater than 3 meters.
- Do not shine light directly into another fixture's lens. Intense beam can damage internal components.
- Direct sunlight or any other strong light beam penetrating the front lens of the luminaire can cause severe internal damage. During unpacking, installation, operation, and extended idle periods outdoors, it is prohibited to expose the front lens of the luminaire to beams of direct sunlight or any other strong light source from any angle.

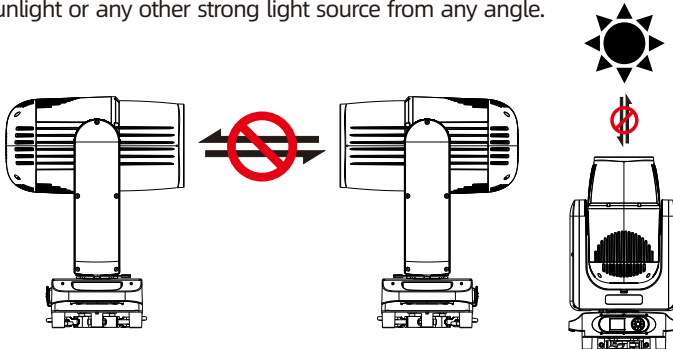

- In the event of serious operating problem, stop using the unit immediately.
- Never turn on and off the unit time after time.
- The housing, the lenses, or the ultraviolet filter must be replaced if they are visibly damaged.

- Do not open the housing as there are no user serviceable parts inside.
- Do not attempt to operate this unit if it becomes damaged. Do not attempt any repairs yourself. Repairs carried out by unskilled people can lead to damage or malfunction. Please contact the nearest authorized technical assistance center if needed.
- Disconnect this product from its power source before servicing.
- Do use the original packaging if the device is to be transported.
- Avoid direct eye exposure to the light source while the product is on.
- Do not operate this product if you see damage on the housing, shields, or cables. Have the damaged parts replaced by an authorized technician at once.

**Installation:**

The luminaire must be securely fastened to the quick-lock hook with screws to prevent vibration or slipping during operation. The supporting structure must be able to withstand 6 times the weight of the luminaire. Additionally, a safety cable must be installed that can endure 30 free-fall drops from 300mm without failure. Installation should only be performed by qualified professionals, and the luminaire must be mounted in an area inaccessible to unauthorized personnel or away from pedestrian traffic.

## 2. Technical Specifications

### OPTICAL

- Light source: 300W white LED module
- Optical angle: 1.77° ( $\phi$ 6.5 standard Beam hole)/1.3° ( $\phi$  5 Beam hole)/0.8° ( $\phi$ 3mm Beam hole)/0.5° ( $\phi$  1.5mm Beam hole), can be flexibly switched.
- Optical lens: coated with high anti reflective film,  $\phi$ 174mm
- Color temperature: 7400K  $\pm$  250K
- Color rendering index: Ra $\geq$ 70
- Illuminance: 60000 lx@10m
- Luminous flux: 3492lm
- LED source life expectancy: 50000 h(\*LED source life depends on several factors, including but not limited to: environmental conditions, control dimming, power supply and voltage, switching cycle, fixture mode, etc.)

### COLOUR

- CMY infinite color mixing
- 14 color chips+white light, capable of achieving bidirectional color rainbow, dual color step gradient (linear movement), bidirectional rotation of color wheel, random color mode.

### PATTERN

- Rotating fixed combination pattern disc: 7 fixed patterns+white circles+7 glass patterns (replaceable), can achieve rotation, flowing, and shaking effects.

### EFFECT

- Prism: 24 prisms+8 prisms, capable of independent bidirectional rotation.
- Soft light effect: mild atomization.
- Electronic dimming: 0-100% linear dimming, uniform light spot.
- The electronic strobe speed is 0.5-25 times/second.
- LED refresh rate: 1000Hz~25KHz

### CONTROL AND PROGRAMMING

- Control channel: 23CH, please refer to the channel table for details.
- Protocol: Standard DMX512 protocol, RDM protocol, sCAN protocol, Art-Net protocol.
- Data connection: Three core or five core signal input/output, (Single or Dual Ethernet Port Optional).
- Display: LCD screen

## **SOFTWARE**

- Upgrade software through DMX signal.
- Intelligent temperature control ensures LED lifespan.
- Silent fan, three working modes(High Output /Standard /Silent).

## **X/Y AXIS MOTION ANGLE**

- X-axis: 540 ° (8-bit/16bit precision scanning)
- Y-axis: infinite rotation
- Reset function with automatic error correction.
- Fixed lock: horizontal/vertical lock.

## **POWER SUPPLY AND POWER**

- Input voltage: AC 100-240V 50/60Hz
- Maximum power: 562W
- Power factor: 0.99
- Maximum current of the lamp: 2.55A/220V, 5.62A/100V

## **DIMENSION**

- Product size: 353 × 232 × 621mm
- N.W.: 22.0 kg
- Carton packaging (default): 425 × 305 × 750mm
- G.W.: 26.1 kg

## **OTHER**

- Protection level: IP66
- Work environment: - 20°C ~ 45°C
- Maximum surface temperature of lamp body: ≤ 60 °C
- Hook: Suitable for pipes with a diameter of 38-52 mm

## **OPTIONAL ACCESSORIES / PACKAGING**

- Flycase Size(2 units ): 650 × 440 × 830mm
- G.W.: 77.4 KG

## **APPROVALS**

- The product implementation standard: IEC 60598-1、IEC 60598-2-17
- Approved certifications: CE、RoHs
- The product complies with the following EU directives:
- Low Voltage Directive 2014/35/EU . EMC Directive 2014/30/EU

## illumination diagram

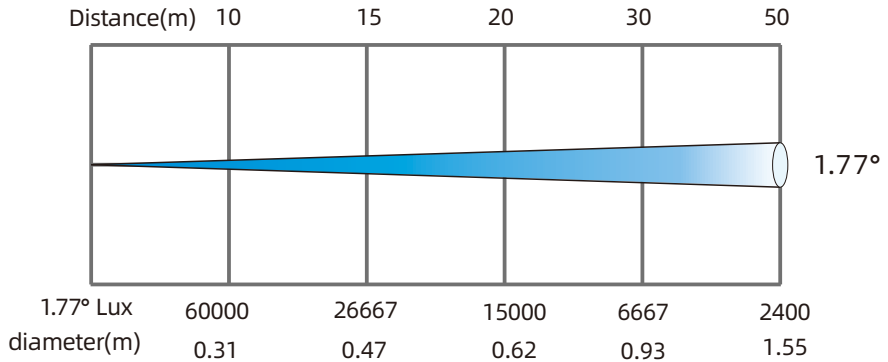

## 2.1.Attachment And Size

### Attachment contents-Fig.1

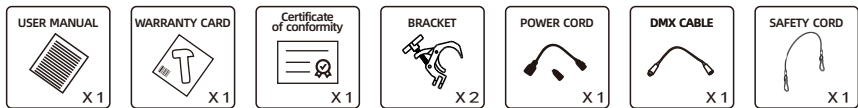

Size-Fig.2(Unit:mm)

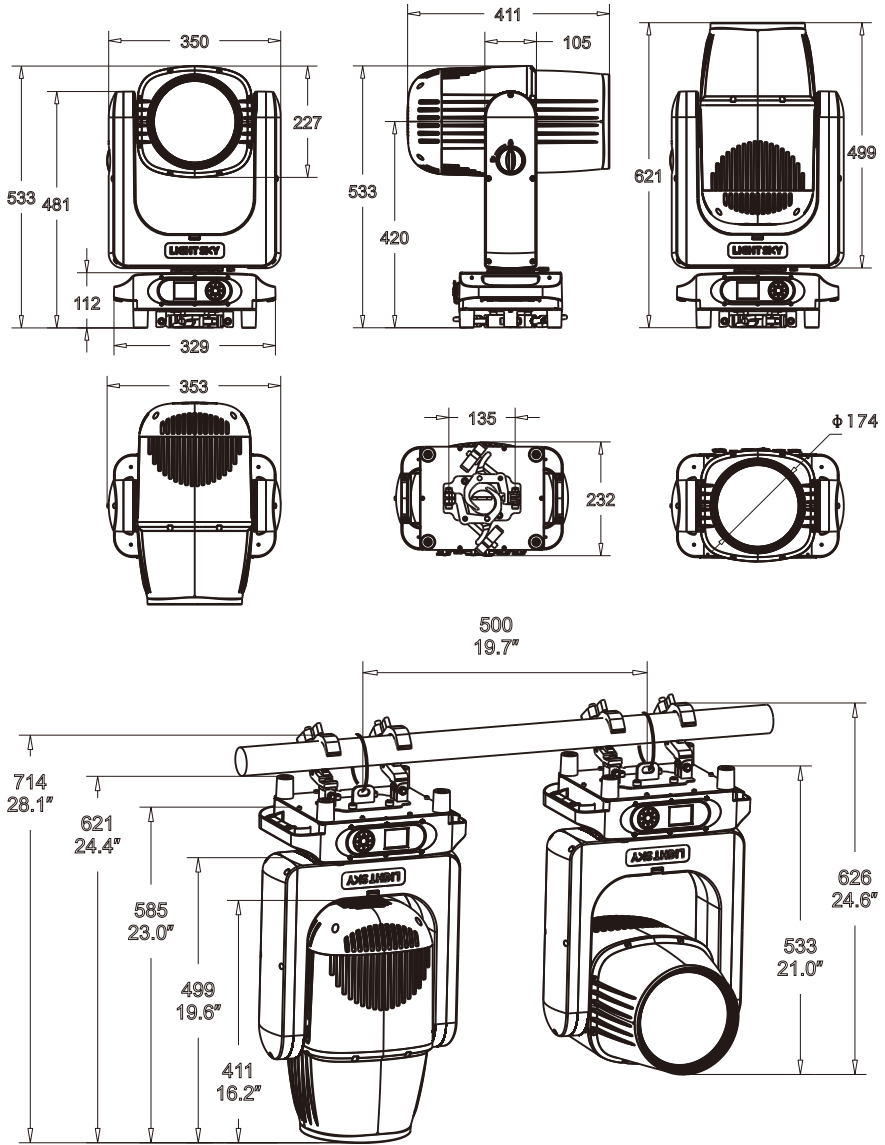

Tilt=0 DMX  
255 DMX

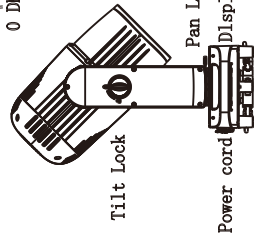

Tilt=128 DMX

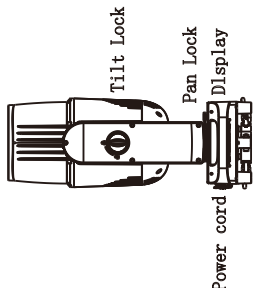

Tilt=255 DMX

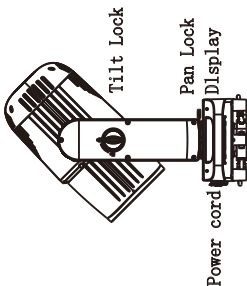

Pan=0 DMX  
255 DMX

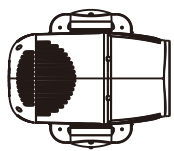

Pan=128 DMX

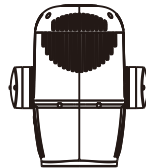

Pan=255 DMX

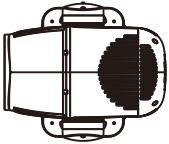

Tilt Rot=0-127 DMX  
(Anticlockwise,  
From fast to slow)

Tilt Rot=128 DMX (STOP)

Tilt Rot=129-255 DMX  
(Clockwise, From  
slow to fast)

### 3.Color/Gobo/Prism

#### CMY-color wheel



CMY



Color

#### Pattern

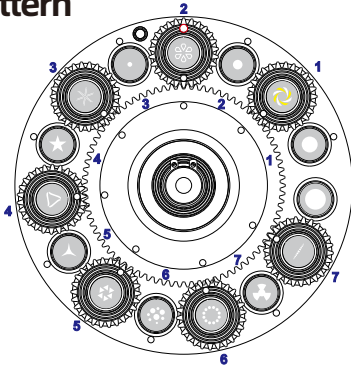

White

#### Glass pattern



#### Metal pattern

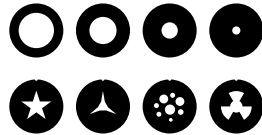

#### Precautions for replacing glass pattern:

1. Black background glass pattern pieces are divided into silver surface and black surface, with the silver surface being the coated surface;
2. When replacing the glass pattern piece, the silver coated surface must be installed facing the direction of the light source (i.e. consistent with the direction of the silver surface of the original pattern piece);
3. When replacing patterned gears, do not replace patterned gears with magnetic beads at will;
4. During installation, it is necessary to strictly follow the order of the pictures and do not arbitrarily change the original order of the pattern pieces.

#### Prism

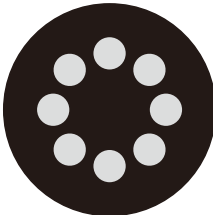

8Prism

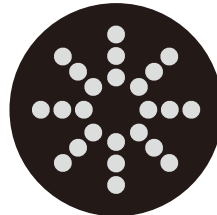

24Prism

## 4.Control Panel

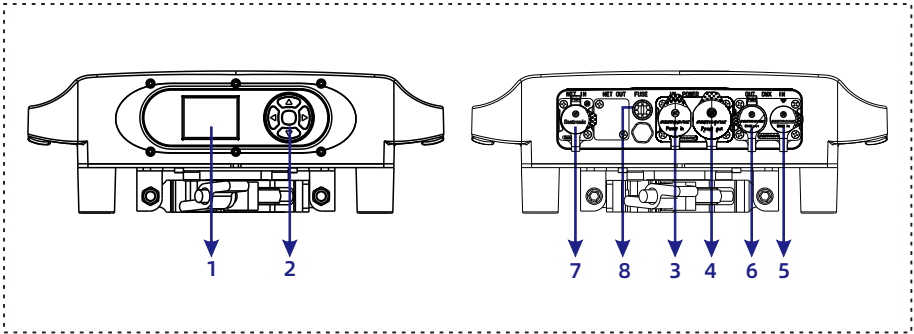

1.Display: To show the various menus and the selected function.

2.Button:

●	OK confirmation key
▲	UP
▼	DOWN
◀	To the left
▶	To the right

3.Power input: Connect the power supply.

4.Power output: Connect the lamp power output adapter.

5.DMX input: Used for DMX512 connection, use 3 core or 5 core XLR signal cable toconnect console and lamps,And input DMX signal.

6.DMX output: Used for DMX512 connection, use 3 core or 5 core XLR signal cable toconnect console and lamps,And output DMX signal.

7.Art-net/USB: The information of the lamp can be transmitted to the main controllerthrough the network cable, and the lamp can be controlled through RJ45(optional). USB optional.

8.Fuse holder: Used for the bottom box battery pack power supply display board when not powered on.(Note: In the case of air transportation, the lighting fixtures will require disassembly of fuses for shipment, and they must be installed by themselves upon receipt.)

## 5.Connection and control

### 5.1.Power supply connection

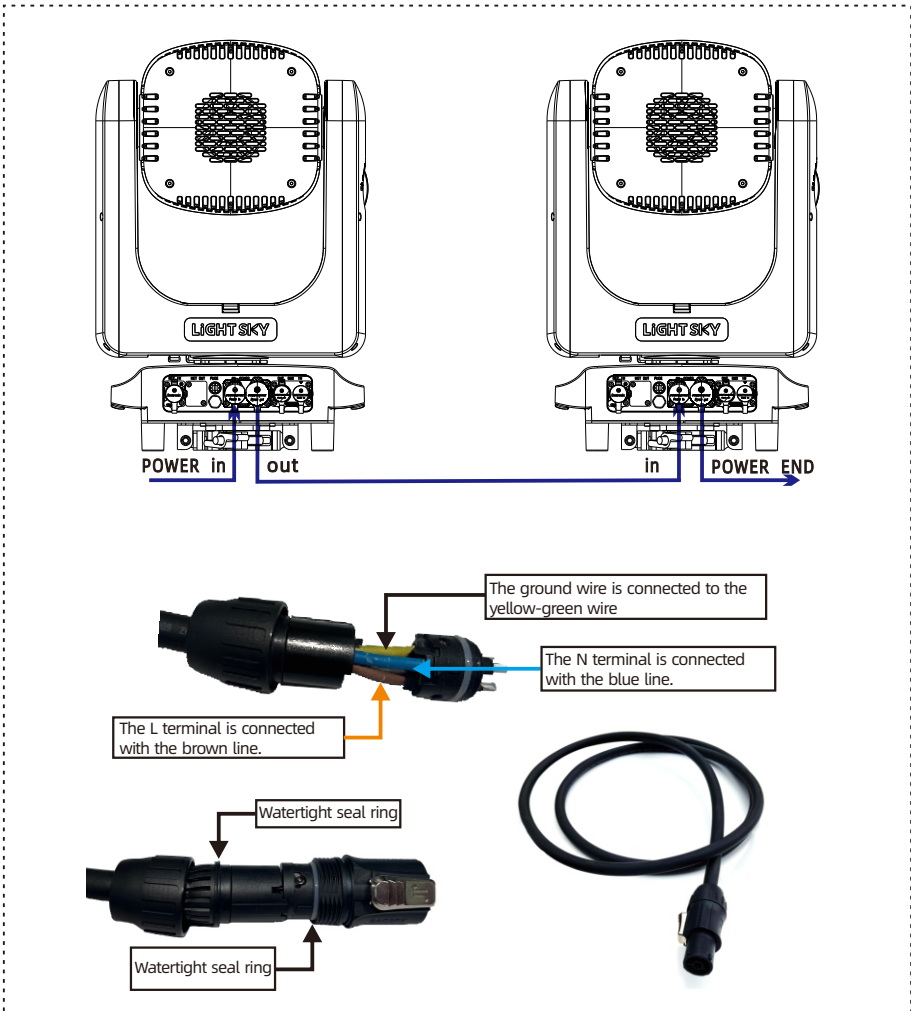

- The bus connecting the power supply must be installed by a qualified professional technician.
- After completing all the above operations and ensuring that it is installed, you can power on the lamp to operate.

## 5.2.DMX 512 Connection

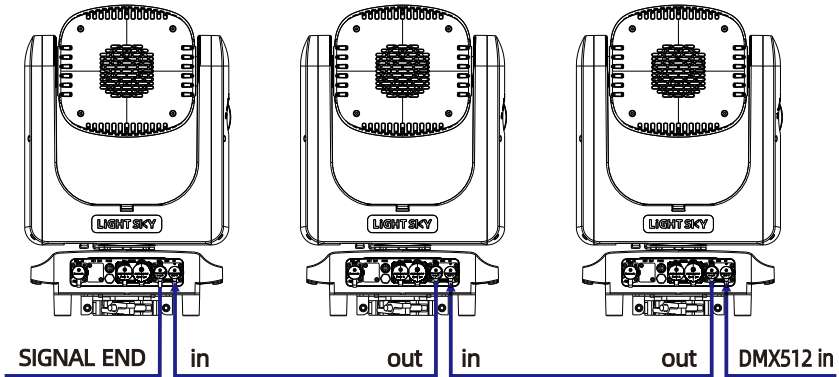

DMX-input



- 1- Shield
- 2- Signal (-)
- 3- Signal (+)
- 4- Not connected
- 5- Not connected



DMX - output



- 1- Shield
- 2- Signal (-)
- 3- Signal (+)
- 4- Not connected
- 5- Not connected



1. At last unit, the DMX cable has to be terminated with a terminator. Solder a 120  $\Omega$  1/4W resistor between pin 2(DMX-) and pin 3(DMX+) into a 3-pin XLR-plug and plug it in the DMX-output of the last unit.
2. Connect the unit together in a “daisy chain” by XLR plug cable from the output of the unit to the input of the next unit. The cable cannot be branched or split to a “Y” cable. DMX 512 is a very high-speed signal. Inadequate or damaged cables, soldered joints or corroded connectors can easily distort the signal and shut down the system.
3. The DMX output and input connectors are pass-through to maintain the DMX circuit, when one of the units' power is disconnected.
4. Each lighting unit needs to have a DMX address to receive the data by the controller. The address number is between 1-512.
5. The end of the DMX 512 system should be terminated to reduce signal errors.
6. 3 pin XLR connectors are more popular than 5 pins XLR.
  - 3 pin XLR: Pin 1: GND, Pin 2: Negative signal (-), Pin 3: Positive signal (+)
  - 5 pin XLR: Pin 1: GND, Pin 2: Negative signal (-), Pin 3: Positive signal (+), Pin4, Pin5 not used.

## 6.How To Set The Unit

### 6.1.Main Function

Main menu	I menu	II menu	III menu	Note	
DMX Address	Address	1-512			
	Channel	23CH			
	State	Black(Default) Hold			
	InputMode	DMX(Default) ARTNET		This menu can only be displayed when the artnet module is connected.	
	DmxAddressLock	OFF ON(Default)			
Information	Time	Total Power Time			
		Power Time			
		Total Light Time			
		Light time			
	Temperature	LED Temp			
		PCB Temp			
	Fan Info.	BaseFanVol			
		ArmFanVol			
		OuterFanVol			
		FocusFanVol			
		BaseFan1Sp			
		ArmFanSp			
		OuterFanSp			
		GoboFanSp			
	Fixture state	FocusFanSp			
		1.MCU(XY) ***			
		2.MCU(LED)***			
		3.MCU(CMY)***			
		4.MCU(Focus)***			
		5.Pan ***			
		6.Tilt ***			
		7.Cyan ***			
		8.Megenta ***			
		9.Yellow ***			
		10.Color ***			
		11.Gobo ***			
		12.GoboRot ***			
		13.Focus ***			
		14.BaseFan ***			
		15.ArmFan ***			
		16.OuterFan ***			
		17.GoboFan ***			
	18.FocusFan ***				
	RDM UID	3888: xxxxxxxx			
	DMX Live	1.Pan ***			
		2.PanFine ***			
		3.Tilt ***			
		4.TiltFine ***			
		5.TiltRot ***			
		6.Function ***			
		7.Cyan ***			
		8.Magenta ***			
		9.Yellow ***			
		10.Color ***			
		11.Fixgobo ***			
		12.Rotgobo ***			
13.Rot ***					
14.Prism1 ***					

Main menu	I menu	II menu	III menu	Note		
		15.Prism1Rot ***				
		16.Prism2 ***				
		17.Prism2Rot ***				
		18.Frost ***				
		19.Focus ***				
		20.FocusFine ***				
		21.Dimmer ***				
		22.DimmerFine ***				
		23.Strobe ***				
		Software	1.Display Ver. Vxxx			
2.XY Ver. Vxxx						
3.LED Ver. Vxxx						
4.CMY Ver. Vxxx						
5.Focus Ver. Vxxx						
Personal	PanTilt Setting	Pan Invert	OFF / ON			
		Tilt Invert	OFF / ON			
		P/T Rectify	OFF / ON			
	Display Setting	Language	EN / ZH			
		Disp. Backlight	OFF(Default)/ ON			
		Disp. Direction	Forward(Default) Reverse			
	Dimmer&Fan Setting	Led Hz	1800Hz			
			3600Hz			
			7200Hz(Default)			
			25000Hz			
		Dimmer Curve	Linear			
			Square(Default)			
			I-Square Scurve			
		Dimmer Speed	Snqp(Default)			
			Fade			
		Fan Mode	HighOutput			
	Standard(Default) Silent					
	Artnet Setting	IP Address	***.***.***.***		This menu can only be displayed when the artnet module is connected.	
		Mask Address	***.***.***.***			
		Universe Address	0-32767			
sACN Universe Address		1-63999				
DHCP		OFF(Default)				
		ON				
Ethernet To DMX	OFF (Default)					
	ON					
Manual Control	Channel control	1.Pan *** ...				
		2.PanFine *** ...				
		3.Tilt *** ...				
		4.TiltFine *** ...				
		5.TiltRot *** ...				
		6.Function *** ...				
		7.Cyan *** ...				
		8.Magenta *** ...				
		9.Yellow *** ...				
		10.Color *** ...				
		11.Fixgobo *** ...				
		12.Rotgobo *** ...				
		13.Rot *** ...				
		14.Prism1 *** ...				
		15.Prism1Rot *** ...				
		16.Prism2 *** ...				

Main menu	I menu	II menu	III menu	Note	
		17.Prism2Rot *** ...			
		18.Frost *** ...			
		19.Focus *** ...			
		20.FocusFine *** ...			
		21.Dimmer *** ...			
		22.DimmerFine *** ...			
		23.Strobe *** ...			
	Reset	PanTilt			
		Head Module			
		All			
	<b>Service</b>	Calibration	1.Pan *** ...		
			2.Tilt *** ...		
			3.Cyan *** ...		
			4.Magenta *** ...		
			5.Yellow *** ...		
			6.Color *** ...		
7.Fixgobo *** ...					
8.Rotgobo *** ...					
9.Rot *** ...					
10.Prism1 *** ...					
11.Prism1Rot *** ...					
12.Prism2 *** ...					
13.Prism2Rot *** ...					
14.Frost *** ...					
15.Focus *** ...					
16.Dimmer***					
Factory Reset		NO / YES			
Reset Timers		1.Total Power Time	NO / YES		
		2.Total Light Time	NO / YES		
		1.Power Time	NO / YES		
		2.Light Time	NO / YES		
Developer		1.Logo Set			
		2.Up Logo			
		3.Language			
	4.Fixture Type				
Firmware update					
<b>Language</b>					
<b>Test</b>	Test PanTilt				
	Test Head Module				
	Test All				
<b>Rotate Display</b>					

## 6.2.Address Setting

Enter MENU, select the DMA setting function, select the address code setting, press the OK button to confirm, and the current DMA address will be displayed in the On screen display. Use the up/down buttons to select addresses 001-512, press the OK button to save the current address code, and return to the previous menu level.

Please refer to the following diagram to address your DMX512 channel for the first 4 units.

Channel mode	Unit 1 Address	Unit 2 Address	Unit 3 Address	Unit 4 Address
23 CH	1	24	47	70

## 6.3.DMX 512 Configuration

Please control the fixture by referring to the configurations below

23 Channel	DMX	Function	Note
1	0--255	Pan positioning	
2	0--255	Fine Pan positioning	
3	0--255	Tilt positioning	
4	0--255	Fine Tilt positioning	
5	0	Tilt Rotation Stop	
	1-127	Forwards tilt rotation fast to slow	
	128	Stop	
	129-255	Backwards tilt rotation slow to fast	
6	0-25	DeviceSet( Hold 3s )	
	26-30	No function	
	31-35	Reset Head	
	36-40	Reset Pan&Tilt	
	41-49	Reset All	
	50-59	No function	
	60-69	Fan HighOutput mode	
	70-79	Fan Standard mode	
	80-84	Fan Silent mode	
	85-89	Dis.Blink off	
	90-129	Dis.Blink on	
	130-139	No function	
	140-149	Pan invert on	
	150-159	Pan invert off	
	160-169	Tilt invert on	
	170-177	Tilt invert off	
	178-185	LED frequency 1.8kHz	
	186-193	LED frequency 3.6kHz	
	194-199	LED frequency 7.2kHz	
	200-204	LED frequency 25kHz	
205-209	Dimmer curve linear		
210-214	Dimmer curve square		
215-219	Dimmer curve inv-square		
220-229	Dimmer curve "S"		
230-239	Dimmer fast		
240-255	Dimmer smooth		
7	0-255	No function	
8	0-255	Cyan	
9	0-255	Magenta	
	0-255	Yellow	
	0-4	ColorWheel1 White	
	5-8	White+Red	

23 Channel	DMX	Function	Note
10	9-12	Red	
	13-17	Red+Orange	
	18-21	Orange	
	22-25	Orange+Aquamarine	
	26-29	Aquamarine	
	30-34	Aquamarine+Green	
	35-38	Green	
	39-42	Green+Light Green	
	43-46	Light Green	
	47-51	Light Green+Lavender	
	52-55	Lavender	
	56-59	Lavender+Pink	
	60-63	Pink	
	64-68	Pink+Yellow	
	69-72	Yellow	
	73-76	Yellow+Rose red	
	77-80	Rose red	
	81-85	Rose red+Blue	
	86-89	Blue	
	90-93	Blue+CTO 260	
	94-98	CTO 260	
99-102	CTO 260+CTO 190		
103-106	CTO 190		
107-110	CTO 190+CTB 8000		
111-115	CTB 8000		
116-119	CTB 8000+Blue		
120-123	Blue		
124-127	Blue+White		
128-190	Forwards ColorWheel rotation fast to slow		
191-192	Stop		
193-255	Backwards ColorWheel rotation slow to fast		
11	0-9	FixgoboWheel	
	10-19	Open	
	20-29	FixGobo 1(Open)	
	30-39	FixGobo 2	
	40-49	FixGobo 3	
	50-59	FixGobo 4	
	60-69	FixGobo 5	
	70-79	FixGobo 6	
	80-87	FixGobo 7	
	88-95	FixGobo1shake,slow to fast	

23 Channel	DMX	Function	Note
	96-103 104-111 112-119 120-127 128-135 136-194 195-196 197-255	FixGobo3 shake,slow to fast FixGobo4 shake,slow to fast FixGobo5 shake,slow to fast FixGobo6 shake,slow to fast FixGobo7 shake,slow to fast Forwards FixGoboWheel rotation fast to slow Stop Backwards FixGoboWheel rotation slow to fast	
12	0-9 10-19 20-29 30-39 40-49 50-59 60-69 70-79 80-87 88-95 96-103 104-111 112-119 120-127 128-135 136-194 195-196 197-255	RotgoboWheel Open RotGobo 1(Open) RotGobo 2 RotGobo 3 RotGobo 4 RotGobo 5 RotGobo 6 RotGobo 7 RotGobo1 shake,slow to fast RotGobo2 shake,slow to fast RotGobo3 shake,slow to fast RotGobo4 shake,slow to fast RotGobo5 shake,slow to fast RotGobo6 shake,slow to fast RotGobo7 shake,slow to fast Forwards RotGoboWheel rotation fast to slow Stop Backwards RotGoboWheel rotation slow to fast	
13	0-127 128-189 190-193 194-255	RotgoboWheelRot GoboRot indexing 0°- 360° Forwards RotGobo rotation fast to slow Stop Backwards RotGobo rotation slow to fast	
14	0-127 128-255	Prism1 Prism out Prism In	
15	0-127 128-190 191-192 193-255	Prism1Rot Prism indexing Forwards prism rotation from fast to slow Stop Backwards prism rotation from slow to fast	
16	0-127	Prism2 Prism out	

23 Channel	DMX	Function	Note
	128-255	Prism In	
17	0-127 128-190 191-192 193-255	Prism2Rot Prism indexing Forwards prism rotation from fast to slow Stop Backwards prism rotation from slow to fast	
18	0-127 128-255	Frost Frost Out Frost In	
19	0-255	Focus 8bit	
20	0-255	FocusFine 16bit	
21	0-255	Dimmer	
22	0-255	Dimmer Fine	
23	0-9 10-49 50-89 90-119 120-179 180-249 250-255	Strobe Strobe closed Slow closing , Fast opening, slow → fast Fast closing , Slow opening, Slow → Fast Slow closing , Slow open, Slow → Fast Random strobe, Slow → Fast Synchronous strobe, slow → fast Strobe open	

## 7. Electrical Connection Diagram

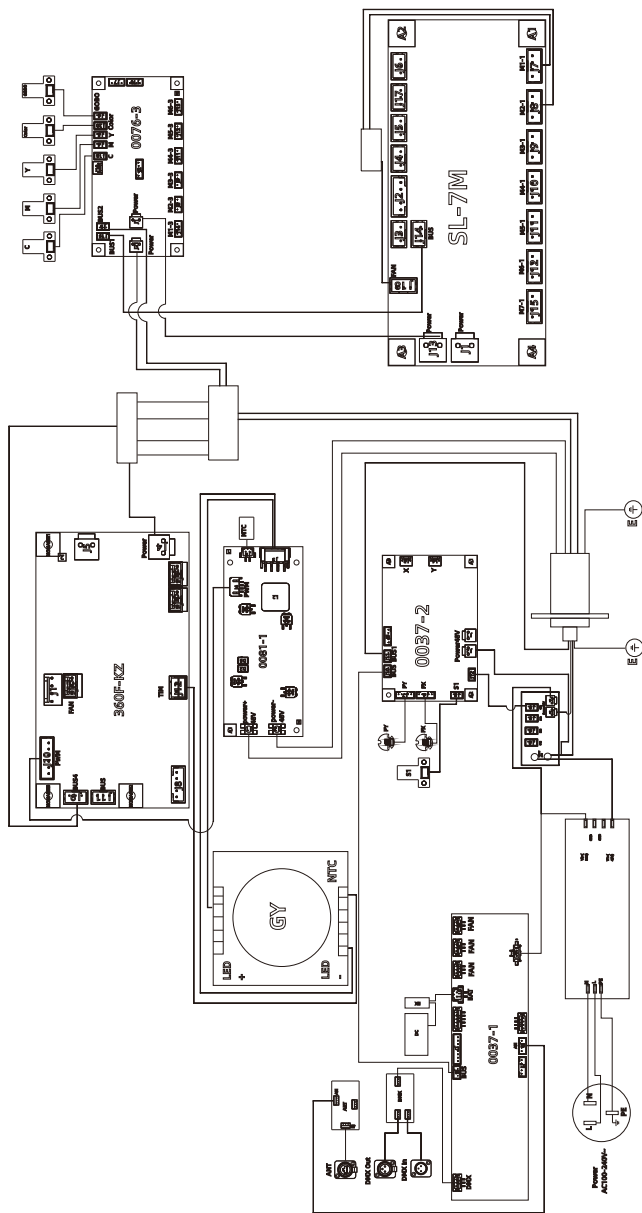

## 8. Troubleshooting

The following are common faults of lamps and corresponding solutions. Faults that cannot be repaired by yourself should be handled by professionally qualified personnel. Disconnect the power supply to the lamp during maintenance!

- The light source is not bright
  - Check that a suitable light source is installed for the luminaire.
  - Check whether the power supply connection of the lamp or the control switch is in poor contact.
  - Check whether the light source has reached the end of its service life or is damaged, and replace it with a high-quality light source of the same specification.
  - Measure whether the power supply is insufficient.
  - Check whether the light source has not cooled down completely due to abnormal operation. Let the lamp cool down for more than 15 minutes to allow the light source to cool down. After returning to the normal start-up range, turn the power on again and it can be used normally.
  - Check whether the DMX512 controller sends a command to turn on the light source.
  - Check whether the light source and trigger circuit are disconnected or defective.
  - Check whether the wiring terminals on the internal trigger are in poor contact and tighten the plug.
  - Check the "Fan Speed and Voltage" in the "Basic Information" menu to see if the speed of FAN1/FAN2/FAN3 is above 500RPN. If it is below 500RPM, the light source will not light up. Replace the fan with the same specification.
  - Check whether the over-temperature protection temperature switch inside the lamp is damaged. Go to the menu "Basic Information" and select "Equipment Temperature" to check - whether the temperature measuring plate shows that the temperature is too high or there is no temperature display.
- The beam appears dim and uneven
  - The light source may have reached the end of its service life and does not emit enough light. Replace it with a light source of the same specification.
  - Check whether there is dust accumulated in the optical part and clean it.
  - Measure whether the power supply is insufficient.
  - Finely adjust the screw device used to change the height of the lamp until the ideal light is achieved. Enter the menu "Service Options" and select "Calibration" to enter color and pattern adjustment, which can be adjusted to the center.
- The projected image is blurry
  - Check whether the DMX512 controller channel value corresponding to the electronic focus system is suitable for the current projection distance.
  - Check whether the mechanical part of the focusing system is stuck, remove the dust and add antifreeze and temperature-resistant lubricating oil.
- The light source of the lamp works intermittently
  - Check whether the fan is running normally or is blocked by dust and paper debris.
  - Check whether the inlet and outlet cooling air vents are blocked by dust.
  - Check whether the lamp has reached the end of its service life.

- Check whether the power supply is insufficient, and whether the power switch and wiring are in poor contact or aging.
- Check whether the over-temperature protection temperature switch inside the lamp is damaged.
- Although it emits light, the lamp does not accept instructions from the controller
- Check whether the digital start address value and function options of the lamp are correct.
- Check whether the connection of the communication control line is correct. The communication line is too long or has been interrupted.
- Check whether the control equipment fails and whether the signal amplifier connected in series fails.
- Check whether the communication line is too long or if other devices interfere with each other.
- Optimize wiring, shorten the length of control signal lines, and route high-voltage and low-voltage lines separately
- Add signal amplifier isolator.
- The signal line is made of high-quality shielded twisted pair (impedance characteristic is  $75\Omega$ ), and the signal terminal resistor is connected at the end of the lamp.
- Check that the circuit board communication IC or CPU is burned out because the bulb performs an abnormal operation when it is not completely cooled, causing the instantaneous ultra-high voltage leakage generated by the trigger, and replace the PCB board.
- The lamp cannot be started
- Check whether the power supply parameters match the lamps.
- Check whether the fuse at the light fixture's power input is blown.
- Check that the lamp has poor contact or falls off due to extrusion deformation, vibration of internal parts, moisture, etc. during long-distance transportation.
- Check whether the internal wires and connectors of the lamp are desoldered or loose.
- Check whether the electrical components of the lamp (such as power switch, transformer, ballast, capacitor, varistor, filter, power supply PCB board, motor control PCB board, etc.) are loose, short-circuited, burned out, etc.
- Some functions of the lamp cannot accept controller instructions
- Check whether the control device sends correct action instructions for these functions.
- Check whether the mechanical parts corresponding to these functions are loose or deformed.
- Check whether the motor sockets corresponding to these functions are loose or the corresponding driver chips are burned out.
- Check whether the motor wires corresponding to these functions are broken at the corners.
- Check whether the motors corresponding to these functions are damaged.
- During operation, the X or Y direction of the lamp does not move normally
- Click the previous step to check one by one.
- Check whether the corresponding drive belts in the X and Y directions of the lamp are detached or broken.
- Check whether the data feedback receiver corresponding to the X and Y directions in the lamp is damaged.
- Restart the computer and reset it once.

## 9. Fixture Cleaning

It is absolutely essential that the fixture is kept clean to ensure the maximum light-output and allow the fixture to function reliably throughout its life. The fixture must be cleaned regularly to avoid dust, dirt and smoke-fluid residues building up on or within the fixture. The cleaning frequency depends on the application environment. Clean the fixture immediately if the dust enters it to avoid damage to the optical lens due to excessive dust.

- A soft lint-free cloth moistened with any good glass cleaning fluid is recommended, under no circumstances should solvents be used.
- Always dry the parts carefully.
- Clean the external optical lens at least every 20 days .



**CAUTION ! ! !**

**Disconnect from mains before starting maintenance operation.**

## 10. Duty exonerative and copyright protectio

- Light source belongs to consumption products, not within the scope of warranty.
- The manufacturer shall not bear any responsibility for any damage caused by failure to operate in accordance with this instruction.
- The manufacturer reserves the right of final interpretation for all information in this manual. For any questions, please refer to the official website.
- All the information in this manual shall not be copied without permission.
- The data contained in this statement are subject to change in the future without prior notice.