

# LIGHT SKY

[www.lightsky.com.cn](http://www.lightsky.com.cn)

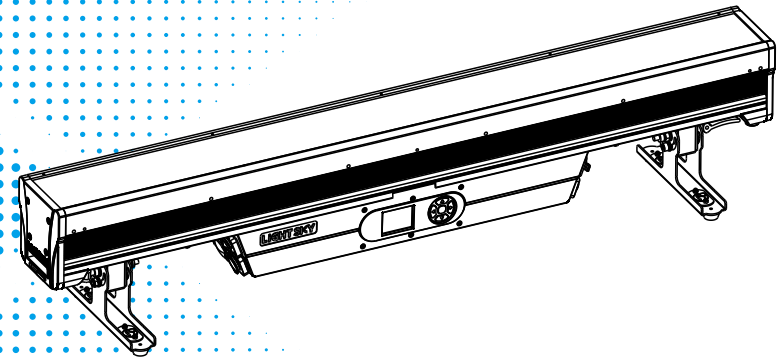

**Fly Dragon Lighting Equipment Co., Ltd.**

Add : NO.4 JINGNENG ROAD 1, HUADU DISTRICT, GUANGZHOU, CHINA.  
Tel : 020-61828288 Fax : 020-61828188 Postal Code : 510820  
Email : flydragon@lightsky.com.cn



Social Media



LIGHT SKY Wechat

## **IP BL1420** **User Manual**

Please read the instruction carefully before use

# CONTENTS

1. Safety Instructions .....	2
2. Technical Specifications .....	5
2.1. Attachment And Size .....	7
3. Connection and control.....	8
3.1. Power supply connection.....	8
3.2. DMX 512 Connection .....	9
3.3. Control Panel .....	10
4. How To Set The Unit .....	11
4.1. Main Function.....	11
4.2. Address Setting .....	13
4.3. DMX 512 Configuration .....	14
5. Electrical Connection Diagram.....	19
6. Troubleshooting .....	20
7. Fixture Cleaning .....	22
8. Duty exonerative and copyright protectio .....	22

**Congratulations on choosing our company product! We thank you for your custom.**

- Please keep in mind that this product, like other products of the company, adheres to the concept of people-oriented design and manufacture, and takes product quality as the foundation.
- We put the interests of customers first, and do our best to meet customer requirements.
- Please read this instruction manual carefully and keep it for future reference. In the case of fully understanding the product information, strictly abide by theUse the instruction manual to ensure that the product is installed, used and serviced correctly and safely.
- Our company is not responsible for any damage to lamps or other performance due to personal failure to follow the instructions during installation, use and maintenance.responsibility.
- Our company reserves the right to modify the manual at any time and without prior notice.

## 1. Safety Instructions



**WARNING**

Please read the instruction carefully which includes important information about the installation, usage and maintenance.

Please keep this User Manual for future consultation. If you sell the unit to another user, be sure that they also receive this manual.

The following symbols are used to identify important safety information on the product and in this manual:

<b>WARNING!</b> Safety hazard. Risk of severe injury or death.	<b>WARNING!</b> Refer to manual before installing, powering or servicing.	<b>WARNING!</b> Hazardous voltage. Risk of severe or lethal electric shock.	<b>WARNING!</b> Fire hazard.	<b>WARNING!</b> Burn hazard. Hot surface. not touch. Do not touch	<b>WARNING!</b> Risk of eye injury. Safety glasses must be worn.	<b>WARNING!</b> Risk of hand injury. Safety gloves must be worn.	<b>WARNING!</b> Avoid direct eye contact
<b>DANGER!</b> Applies only to luminaires directly mounted on surfaces of non-combustible materials	<b>DANGER!</b> Do not discard Trash can	<b>DANGER!</b> Mark of ground	<b>DANGER!</b> Replace all shatter shields	<b>DANGER!</b> Take a short distance from the object to be photographed (meters)	<b>DANGER!</b> Rated maximum ambient temperature	<b>DANGER!</b> Do not point the lens towards the sun or strong light	<b>DANGER!</b> Operation not allowed during runtime

### Important:

**Damages caused by the disregard of this user manual are not subject to warranty. The dealer will not accept liability for any resulting defects or problems.**

- Unpack and check carefully to ensure that there is no transportation damage before using the unit.
- Do install and operate by qualified operator.
- The light source in this luminaire should be replaced by the manufacturer or its service agent or a similarly qualified person, always cut off the power supply before replacing he light source.
- Do not allow children to operate the fixture.
- The unit must be installed in a location with adequate ventilation, at least 50cm from adjacent surfaces.
- Be sure that no ventilation slots is blocked, otherwise the unit will be overheated.

- Before operation, ensure that you are connecting this product to the proper voltage in accordance with the specifications in this manual or on the product's specification label.
- It's important to ground the yellow/green conductor to earth in order to avoid electric shock.
- Minimum ambient temperature Ta: -20°C. Maximum ambient temperature Ta: 45°C.
- Do not operate this product at a lower or higher temperature.
- Do not connect the device to any dimmer pack.
- When the lamp is running, do not place combustible objects next to it. The shortest distance between the device and inflammable and explosive objects or materials is 1 m.
- Make sure the power cord is not crimped or damaged; replace it immediately if damaged.
- Unit's surface temperature may reach up to 65°C. Do not touch the housing bare-handed during its operation.
- Avoid any flammable liquids, water or metal from entering the unit. Once it happens, cut off the mains power immediately.
- Do not operate in a dirty or dusty environment. Do clean the fixture regularly.
- Do not touch any wire during operation as there might be a hazard of electric shock.
- Avoid entanglement of the power cord with other wires.
- The minimum distance to objects/surface must be more than 3 meters.
- In the event of serious operating problem, stop using the unit immediately.
- Never turn on and off the unit time after time.
- The housing, the lenses, or the ultraviolet filter must be replaced if they are visibly damaged.
- Do not open the housing as there are no user serviceable parts inside.
- Do not attempt to operate this unit if it becomes damaged. Do not attempt any repairs yourself. Repairs carried out by unskilled people can lead to damage or malfunction. Please contact the nearest authorized technical assistance center if needed.
- Disconnect this product from its power source before servicing.
- Do use the original packaging if the device is to be transported.
- Avoid direct eye exposure to the light source while the product is on.
- Do not operate this product if you see damage on the housing, shields, or cables. Have the damaged parts replaced by an authorized technician at once.

**Installation:**

The luminaire must be securely fastened to the quick-lock hook with screws to prevent vibration or slipping during operation. The supporting structure must be able to withstand 6 times the weight of the luminaire. Additionally, a safety cable must be installed that can endure 30 free-fall drops from 300mm without failure. Installation should only be performed by qualified professionals, and the luminaire must be mounted in an area inaccessible to unauthorized personnel or away from pedestrian traffic.

## 2. Technical Specifications

### OPTICS

- Light source: 14x20 RGBA LED
- Beam angle: 28 ° Spot angle: 60 °
- Color temperature: 2500K-10000K
- Illuminance: 1124 lx @ 5m
- Luminous flux: 11347 lm
- Average lifespan of light source: 20000 h

### EFFECT

- Color Mixing System: Uniform RGBA Color Mixing System and Rainbow Effect.
- Control: The light source supports color/white light partition control, with outstanding transformation effects.
- Effect macros: static effect macros and dynamic effect macros functions.
- Dimming: Electronic dimming, providing four dimming curves.
- Strobe: 1-25Hz electronic flicker and random flicker.

### CONTROL AND PROGRAMMING

- Control channels: 16CH (Default), 68CH, see channel table for details.
- Control Protocol: Standard DMX512 protocol, RDM protocol, Art-Net protocol (optional), sACN protocol (optional).
- Data connection: Three core (default) or five core signal input/output, RJ45 network port input/output (optional).
- Display: LCD screen

### SOFTWARE

- Upgrade software through DMX signal interface.
- Intelligent temperature control ensures LED lifespan.

### POWER

- Input voltage: AC 100-240V 50~60Hz
- Power: 343W
- Power factor: greater than 0.93
- Maximum current of the lamp: 1.6A/220V; 3.4A/100V

### DIMENSIONS & WEIGHT

- Product size: 1008 × 191 × 211mm
- N.W.: 12.0 kg
- Carton packaging (Default): 1100 × 310 × 240mm
- G.W.: 16.2 kg

**OTHER**

- Protection level: IP66
- Working environment: -20 °C~45 °C
- Maximum surface temperature of lamp body: 65 °C
- Built-in splicing lock, enabling quick alignment and connection

**OPTIONAL ACCESSORIES**

- Barn doors
- Frost filters: C-HE20, C-HE30, C-HE40, C-HE55

**APPROVALS**

- The product implementation standard: IEC 60598-1、IEC 60598-2-17
- Approved certifications: CE、RoHs
- The product complies with the following EU directives:  
Low Voltage Directive 2014/35/EU . EMC Directive 2014/30/EU

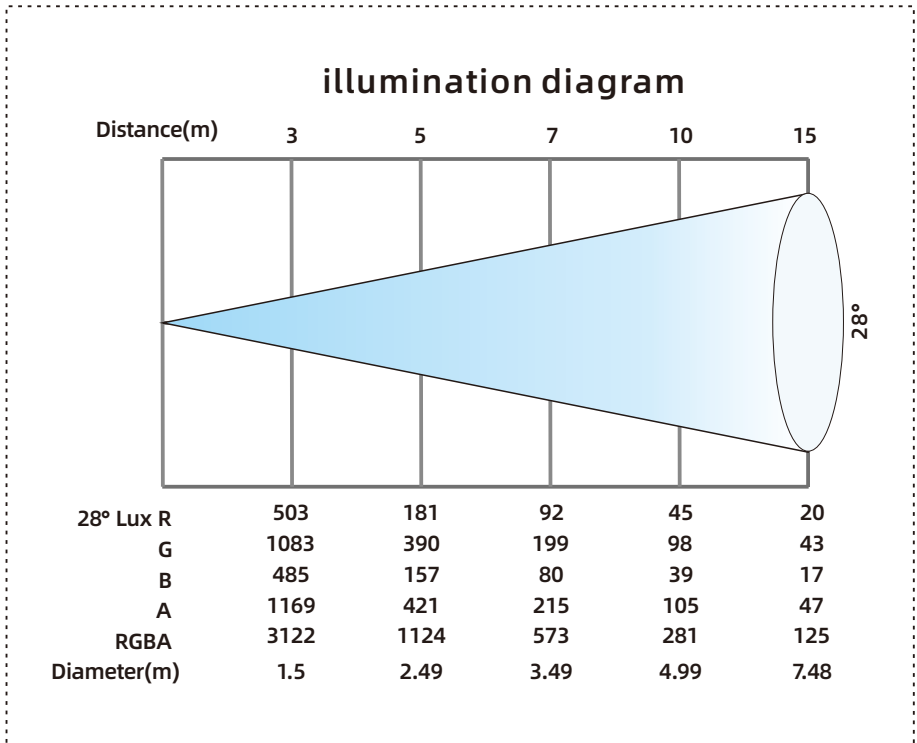

## 2.1.Attachment And Size

Attachment contents-Fig.1

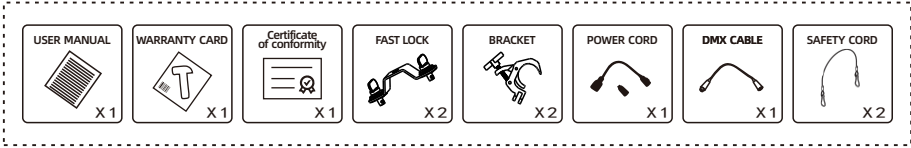

Size-Fig.2 (Unit:mm)

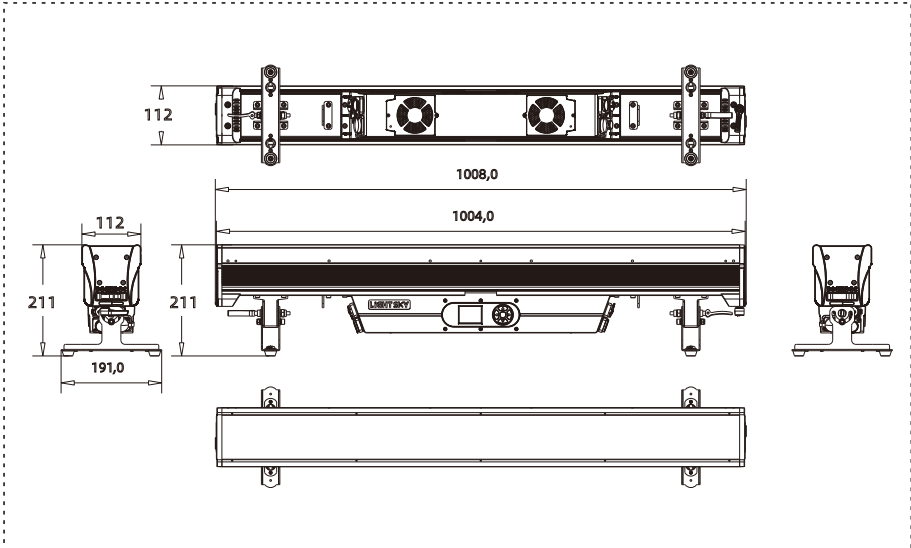

### 3.Connection and control

#### 3.1.Power supply connection

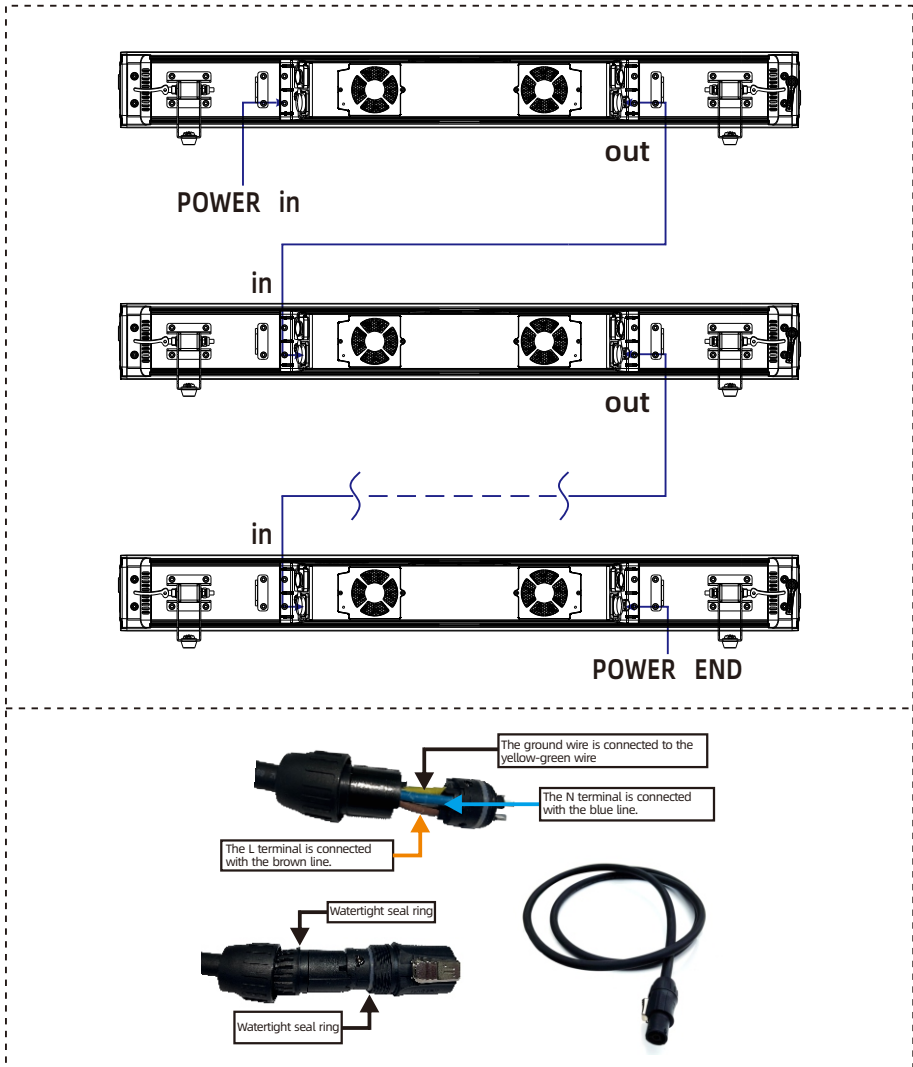

- The bus connecting the power supply must be installed by a qualified professional technician.
- After completing all the above operations and ensuring that it is installed, you can power on the lamp to operate.

## 3.2.DMX 512 Connection

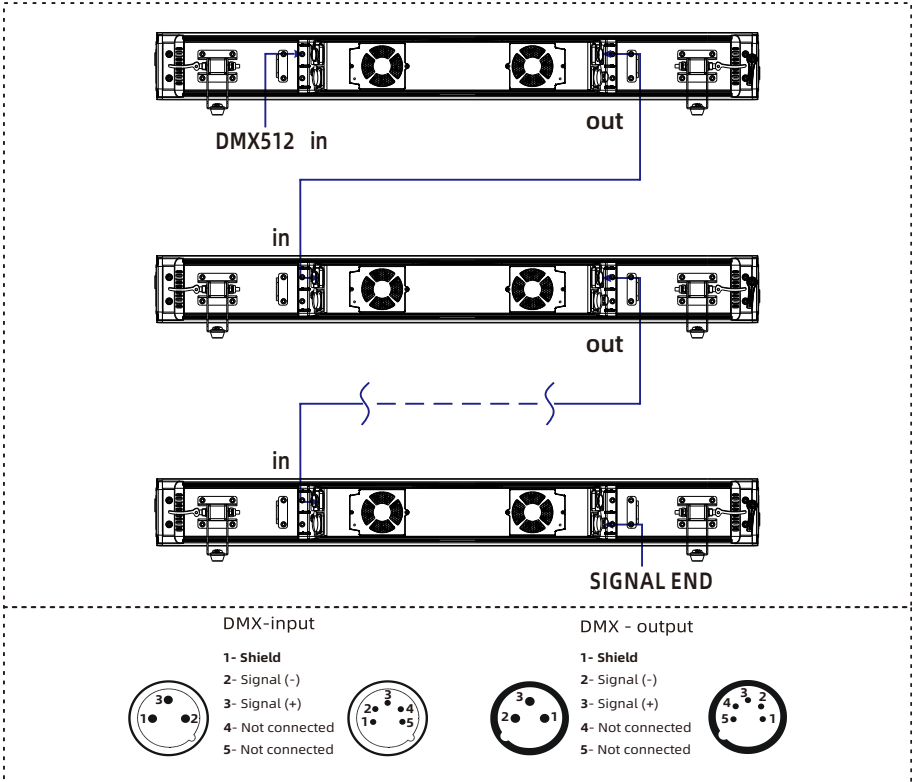

1. At last unit, the DMX cable has to be terminated with a terminator. Solder a 120 Ω 1/4W resistor between pin 2(DMX-) and pin 3(DMX+) into a 3-pin XLR-plug and plug it in the DMX-output of the last unit.
2. Connect the unit together in a “daisy chain” by XLR plug cable from the output of the unit to the input of the next unit. The cable cannot be branched or split to a “Y” cable. DMX 512 is a very high-speed signal. Inadequate or damaged cables, soldered joints or corroded connectors can easily distort the signal and shut down the system.
3. The DMX output and input connectors are pass-through to maintain the DMX circuit, when one of the units' power is disconnected.
4. Each lighting unit needs to have a DMX address to receive the data by the controller. The address number is between 1-512.
5. The end of the DMX 512 system should be terminated to reduce signal errors.
6. 3 pin XLR connectors are more popular than 5 pins XLR.
  - 3 pin XLR: Pin 1: GND, Pin 2: Negative signal (-), Pin 3: Positive signal (+)
  - 5 pin XLR: Pin 1: GND, Pin 2: Negative signal (-), Pin 3: Positive signal (+), Pin4, Pin5 not used.

### 3.3.Control Panel

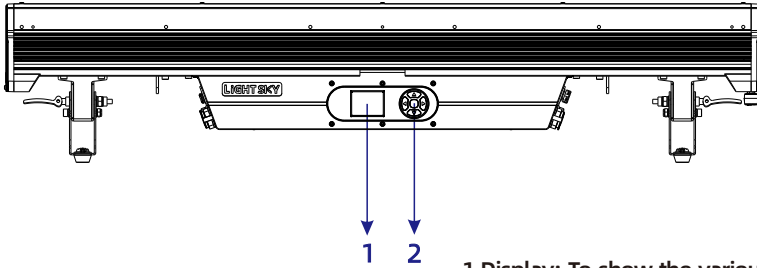

1.Display: To show the various menus and the selected function.

2.Button :

OK	OK confirmation key
▲	UP
▼	DOWN
◀	To the left
▶	To the right

**Installation orientation instructions:** To achieve uniform wall lighting effect, please ensure that the diffuser plane is close to the wall and the concave and convex surfaces are away from the wall during installation;At the same time, the lamp should be vertically aligned with the light emitting surface 100mm away from the wall. This is the standard installation method, which can achieve the most uniform and soft spot effect.

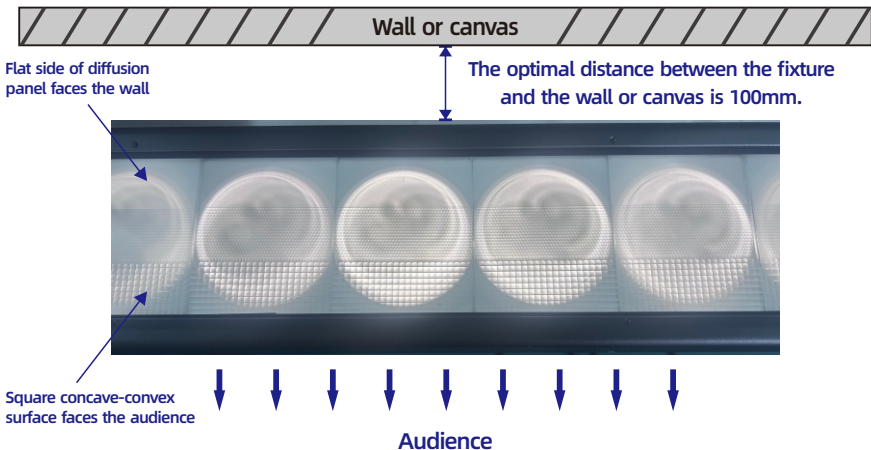

## 4. How To Set The Unit

### 4.1. Main Function

The main functions are as follows:

Main menu	I menu	II menu	III menu
DMX Setting	1.Address	1-512	
	2.Channel	16CH (Default)	
		68CH	
	3.State	Black (Default)	
		Hold	
Scene			
4.InputMode	Dmx (Default)		
	ARTNET sACN	Art-Net can only be selected when an Art-Net module is installed.	
5.DmxAddressLock	OFF		
	ON (Default)		
Information	1.Time	1.Total Power Time	
		2.Power Time	
		3.Total light Time	
		4.Light Time	
	2.Temperature	1.Led Temp	
	3.Fan Info.	1.FanVol	
		2.Fan1Sp	
		3.Fan2Sp	
	4.Fixture state	1.Fan1	
		2.Fan2	
	5.RDM UID	3888: xxxxxxxx	
	6.DMX Live	1.Dimmer ***	
		2.Dimmer Fine ***	
3.Strobe ***			
4....			
7.Software	1.Disp. Ver. Vxxx		
	2.ETH. Ver. Vxxx		
Personality	1.Dimmer&Fan Setting	1.Dimmer Curve	Linear
			Square (Default)
			I-Square
			Curve
		2.Dimmer Freq	1800Hz
			3600Hz (Default)
			7200Hz 25000Hz
		3.Dimmer Speed	Normal (Default)
			Smooth1
			Smooth2 Smooth3
		4.Fan Mode	HighOutput
			Standard (Default) Silent
	5.Led Invert	OFF (Default)	
		ON	
1.Language	EN (Default)		
	ZH		

Main menu	I menu	II menu	III menu
	2.Display Setting	2.Dis. Backlight	OFF (Default) ON
		3.Dis. Direction	Forward (Default) Reverse
		4.Dis. Blink	OFF ON (Default)
	3.Ethernet Setting (This menu is only displayed when an Art-Net module is installed.)	IP Address	***.***.***.***
		Mask Address	***.***.***.***
		Universe Address	0-32767
		sACN Universe Address	1-63999
		DHCP	OFF (Default) ON
		Ethernet To DMX	OFF (Default) ON
	Manual Control	1.Channel control	1.Dimmer ***
2.Dimmer Fine ***			
3.Strobe ***			
4....			
2.Scene Edit		1.Dimmer ***	
		2.Dimmer Fine ***	
		3.Strobe ***	
		4....	
Service	1.Calibrate	1.Red1 ***	
		2.Green1 ***	
		3.Blue1 ***	
		4.Amber1 ***	
		5.....	
	2.Factory Reset	NO / YES	Password: 1111
	3.Reset Timers	1.Total Power Time	NO / YES
		2.Total Light Time	NO / YES
		1.Power Time	NO / YES
		2.Light Time	NO / YES
4.Developer			
5.Firmware update			
Language	EN		
	ZH		
Test	1.Test All	Running:Step ***/**	
Rotate Display	Normal		
	Rotate 180		

## 4.2.Address Setting

Enter MENU, select the DMX setting function, select the address code setting, press the OK button to confirm, the current DMX address will be displayed on the display. Use the up/down buttons to select addresses 001~512, and press the OK button to save. Press the OK button to return to the previous menu.

Please refer to the following diagram to address your DMX512 channel for the first 4 units.

Channel mode	Unit 1 Address	Unit 2 Address	Unit 3 Address	Unit 4 Address
16 CH	1	17	33	49
68 CH	1	69	137	205

### 4.3.DMX 512 Configuration

Standard 16CH	Extended 68 CH	DMX	FUNCTION	Note
1	1	0-255	<b>Dimmer</b> Dimmer from Dark To Bright	
2	2	0-255	<b>Dimmer Fine</b> Dimmer Fine	
3	3	0-9 10-49 50-89 90-119 120-179 180-249 250-255	<b>Strobe</b> Strobe open Slow closing , Fast opening , slow → fast Fast closing , Slow opening , Slow → Fast Slow closing , Slow open , Slow → Fast Random strobe,Slow → Fast Synchronous strobe,slow → fast Strobe open	
4	4	10-49 50-59 60-69 70-79 80-84 85-89 90-94 95-99 100-169 170-177 178-185 186-193 194-199 200-204 205-209 210-214 215-219 220-224 225-229 230-234 235-239 240-255	<b>Function(Hold 3s)</b> No function Fan high output Fan Standard Fan Silent Display Blink off Display Blink on Led Invert off Led Invert on No function LED frequency 1.8kHz LED frequency 3.6kHz LED frequency 7.2kHz LED frequency 25kHz Dimmer curve linear Dimmer curve square Dimmer curve inv-square Dimmer curve "S" Dimmer Speed Normal Dimmer Speed smooth1 Dimmer Speed smooth2 Dimmer Speed smooth3 No function	
		0-5 6 7 8 9 10 11 12 13 14 15 16 17 18 19 20 21	<b>Color Macro</b> Macro No Function 10000K 9500K 9000K 8500K 8000K 7500K 7000K 6500K 6000K 5600K 5000K 4500K 4000K 3700K Filter 4 (Medium Bastard Amber) Filter 10 (Medium Yellow)	

Standard 16CH	Extended 68 CH	DMX	FUNCTION	Note
		22	Filter 19 (Fire)	
		23	Filter 26 (Bright Red)	
		24	Filter 58 (Lavender)	
		25	Filter 68 (Sky Blue)	
		26	Filter 79 (Just Blue)	
		27	Filter 88 (Lime Green)	
		28	Filter 90 (Dark Yellow Green)	
		29	Filter 100 (Spring Yellow)	
		30	Filter 101 (Yellow)	
		31	Filter 102 (Light Amber)	
		32	Filter 103 (Straw)	
		33	Filter 104 (Deep Amber)	
		34	Filter 105 (Orange)	
		35	Filter 106 (Primary Red)	
		36	Filter 111 (Dark Pink)	
		37	Filter 113 (magenta)	
		38	Filter 115 (Peacock Blue)	
		39	Filter 116 (Medium Blue-Green)	
		40	Filter 117 (Steel Blue)	
		41	Filter 118 (Light Blue)	
		42	Filter 121 (Filter Green)	
		43	Filter 124 (Dark Green)	
		44	Filter 128(Bright Pink)	
		45	Filter 131 (Marine Blue)	
		46	Filter 132 (Medium Blue)	
		47	Filter 134 (Golden Amber)	
		48	Filter 135 (Deep Golden Amber)	
		49	Filter 136 (Pale Lavender)	
		50	Filter 137 (Special Lavender)	
		51	Filter 138 (Pale Green)	
		52	Filter 139 (Primary Green)	
		53	Filter 141 (Bright Blue)	
		54	Filter 147 (Apricot)	
		55	Filter 148 (Bright Rose)	
		56	Filter 152 (Pale Gold)	
		57	Filter 154 (Pale Rose)	
		58	Filter 157 (Pink)	
		59	Filter 158 (Deep Orange)	
		60	Filter 162 (Bastard Amber)	
		61	Filter 164 (Flame Red)	
		62	Filter 165 (Daylight Blue)	
		63	Filter 169 (Lilac Tint)	
		64	Filter 170 (Deep Lavender)	
		65	Filter 172 (Lagoon Blue)	
		66	Filter 179 (Chrome Orange)	
		67	Filter 197 (Alice Blue)	
		68	Filter 201 (Full C.T. Blue)	
		69	Filter 202 (Half C.T. Blue)	
		70	Filter 203 (Quarter C.T. Blue)	
		71	Filter 204 (Full C.T. Orange)	
		72	Filter 205 (Half C.T. Orange)	
		73	Filter 206 (Quarter C.T. Orange)	
		74	Filter 243 (LEE Fluorescent 3600 Kelvin)	
		75	Filter 244 (green plus)	

Standard 16CH	Extended 68 CH	DMX	FUNCTION	Note	
5	5	76	Filter 247 (Filter Minus Green)		
		77	Filter 248 (Half Minus Green)		
		78	Filter 281 (Three Quarter C.T. Blue)		
		79	Filter 285 (Three Quarter C.T. Orange)		
		80	Filter 287 (Double C.T. Orange)		
		81	Filter 322 (Soft Green)		
		82	Filter 352 (Glacier Blue)		
		83	Filter 353 (Lighter Blue)		
		84	Filter 505 (Sally Green)		
		85	Filter 651 (HI Sodium)		
		86	Filter 778 (Millennium Gold)		
		87	Filter 793 (Vanity Fair)		
				Local Color	
		88	101 Purple Peony		
		89	104 Magenta		
		90	109 Cherry Purple		
		91	110 Azalea Purple		
		92	112 Lotus Red		
		93	113 Wild Rose Pink		
		94	114 Ravishing Red		
		95	115 Pink Coral		
		96	116 Crape Myrtle		
		97	118 Redbud Purple		
		98	203 Red Rose		
		99	205 Burnt Orange		
		100	208 Dawn Red		
		101	209 Vermilion		
		102	210 Bright Rose		
		103	211 Carmine Red		
		104	212 Sunset Red		
		105	213 Light Pink		
		106	216 Cherry Red		
		107	218 Orange Pink		
		108	220 Begonia Red		
		109	222 Apricot White		
		110	302 Red Orange		
		111	305 Amber		
		112	306 Marigold Yellow		
		113	309 Sea Breeze Pink		
		114	311 Light Vermilion		
		115	402 Imperial Yellow		
		116	403 Lemon Yellow		
		117	405 Bright Amber		
		118	406 Wheat Yellow		
		119	408 Light Yellow		
		120	410 Bright Yellow		
		121	412 Ivory White		
		122	502 Mung Bean Gree		
123	506 Chive Yellow				
124	507 Bright Yellow-Green				
125	510 Mung Bean Green				
126	601 Emerald Green				
127	602 Parrot Green				
128	604 Fresh Bamboo				

Standard 16CH	Extended 68 CH	DMX	FUNCTION	Note
		129	607 Verdant Green	
		130	608 Grass Green	
		131	611 Jade Green	
		132	613 Apple Green	
		133	614 Emerald-Tinted Green	
		134	616 Mint Green	
		135	705 South China Sea	
		136	708 Light Green	
		137	711 Sinomenium acutum	
		138	713 Blue-Green	
		139	714 Sky Blue	
		140	717 Light Blue	
		141	719 Azure	
		142	720 Smoke Cyan	
		143	804 Ultramarine Blue	
		144	806 Deep Ocean Blue	
		145	814 Bright Blu	
		146	908 Dusk Purple	
		147	911 Lavender	
		148	912 Light Lavender	
		149	1012 NI SHANG Purple	
		150-192	Reserved	
			Color Effect	
		193-202	Color wheel change speed from fast to slow	
		203-212	Color wheel change speed from fast to slow	
		213-222	Color wheel change speed from fast to slow	
		223-232	Color wheel change speed from fast to slow	
		233-242	Rainbow color speed from slow to fast	
		243-252	Rainbow color speed from slow to fast	
		253-255	Rainbow color speed from slow to fast	
			<b>CCT</b>	
		0-2	No Function	
		3-255	CCT Color 10000K-2500K	
		3	10000K	
		23	9500K	
		43	9000K	
		63	8500K	
		83	8000K	
		103	7500K	
		120	7000K	
		135	6500K	
		150	6000K	
		162	5600K	
		180	5000K	
		195	4500K	
		210	4000K	
		219	3700K	
		225	3500K	
		234	3200K	
		240	3000K	
		249	2700K	
		255	2500K	
			<b>Static Macro</b>	
		0-7	No Function	
		8-212	Static Scene 1-205	
		213-255	No Function	
6	6			
7	7			

Standard 16CH	Extended 68 CH	DMX	FUNCTION	Note
8	8	0-7 8-107 108-255	<b>Effect Macro</b> No Function Dynamic scene 1-50(2 dmx for every scene) No Function	
9	9	0-125 126-129 130-255	<b>Effect Speed</b> Forwards move led effect speed from fast to Stop slow Backwards move led effect speed from slow to fast	
10	10	0-255	<b>Effect Fade</b> effect delay from fast to slow	
11	11	0-1 2-255	<b>Background Color</b> No Function Color for background	
12	12	0-255	<b>Background Dim</b> Background Dimmer 0 to 100% (0=default)	
13	\	0-255	<b>Red</b> Red 0 to 100%	
14	\	0-255	<b>Green</b> Green 0 to 100%	
15	\	0-255	<b>Blue</b> Blue 0 to 100%	
16	\	0-255	<b>Amber</b> Amber 0 to 100%	
\	13	0-255	<b>Red 1</b> Red 1 0 to 100%	
\	14	0-255	<b>Green 1</b> Green 1 0 to 100%	
\	15	0-255	<b>Blue 1</b> Blue 1 0 to 100%	
\	16	0-255	<b>Amber 1</b> Amber 1 0 to 100%	
...	...	0-255	...	
\	65	0-255	<b>Red 14</b> Red 14 0 to 100%	
\	66	0-255	<b>Green 14</b> Green 14 0 to 100%	
\	67	0-255	<b>Blue 14</b> Blue 14 0 to 100%	
\	68	0-255	<b>Amber 14</b> Amber 14 0 to 100%	

## 5. Electrical Connection Diagram

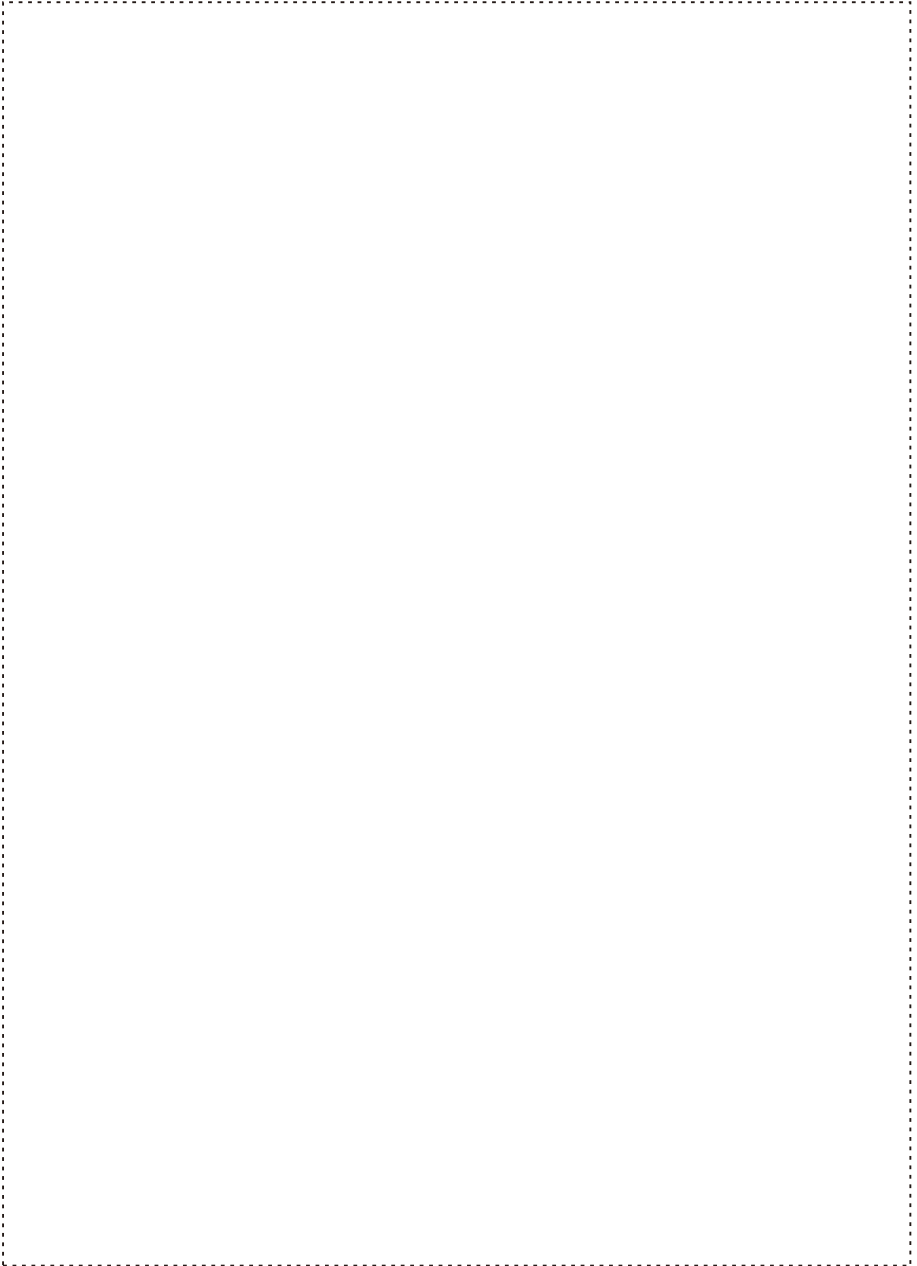

## 6. Troubleshooting

The following are common faults of lamps and corresponding solutions. Faults that cannot be repaired by yourself should be handled by professionally qualified personnel. Disconnect the power supply to the lamp during maintenance!

- The light source is not bright
  - Check that a suitable light source is installed for the luminaire.
  - Check whether the power supply connection of the lamp or the control switch is in poor contact.
  - Check whether the light source has reached the end of its service life or is damaged, and replace it with a high-quality light source of the same specification.
  - Measure whether the power supply is insufficient.
  - Check whether the light source has not cooled down completely due to abnormal operation. Let the lamp cool down for more than 15 minutes to allow the light source to cool down. After returning to the normal start-up range, turn the power on again and it can be used normally.
  - Check whether the DMX512 controller sends a command to turn on the light source.
  - Check whether the light source and trigger circuit are disconnected or defective.
  - Check whether the wiring terminals on the internal trigger are in poor contact and tighten the plug.
  - Check the "Fan Speed and Voltage" in the "Basic Information" menu to see if the speed of FAN1/FAN2/FAN3 is above 500RPN. If it is below 500RPM, the light source will not light up. Replace the fan with the same specification.
  - Check whether the over-temperature protection temperature switch inside the lamp is damaged. Go to the menu "Basic Information" and select "Equipment Temperature" to check - whether the temperature measuring plate shows that the temperature is too high or there is no temperature display.
- The beam appears dim and uneven
  - The light source may have reached the end of its service life and does not emit enough light. Replace it with a light source of the same specification.
  - Check whether there is dust accumulated in the optical part and clean it.
  - Measure whether the power supply is insufficient.
  - Finely adjust the screw device used to change the height of the lamp until the ideal light is achieved. Enter the menu "Service Options" and select "Calibration" to enter color and pattern adjustment, which can be adjusted to the center.
- The projected image is blurry
  - Check whether the DMX512 controller channel value corresponding to the electronic focus system is suitable for the current projection distance.
  - Check whether the mechanical part of the focusing system is stuck, remove the dust and add antifreeze and temperature-resistant lubricating oil.
- The light source of the lamp works intermittently
  - Check whether the fan is running normally or is blocked by dust and paper debris.
  - Check whether the inlet and outlet cooling air vents are blocked by dust.
  - Check whether the lamp has reached the end of its service life.

- Check whether the power supply is insufficient, and whether the power switch and wiring are in poor contact or aging.
- Check whether the over-temperature protection temperature switch inside the lamp is damaged.
- Although it emits light, the lamp does not accept instructions from the controller
- Check whether the digital start address value and function options of the lamp are correct.
- Check whether the connection of the communication control line is correct. The communication line is too long or has been interrupted.
- Check whether the control equipment fails and whether the signal amplifier connected in series fails.
- Check whether the communication line is too long or if other devices interfere with each other.
- Optimize wiring, shorten the length of control signal lines, and route high-voltage and low-voltage lines separately
- Add signal amplifier isolator.
- The signal line is made of high-quality shielded twisted pair (impedance characteristic is  $75\Omega$ ), and the signal terminal resistor is connected at the end of the lamp.
- Check that the circuit board communication IC or CPU is burned out because the bulb performs an abnormal operation when it is not completely cooled, causing the instantaneous ultra-high voltage leakage generated by the trigger, and replace the PCB board.
- The lamp cannot be started
- Check whether the power supply parameters match the lamps.
- Check whether the fuse at the light fixture's power input is blown.
- Check that the lamp has poor contact or falls off due to extrusion deformation, vibration of internal parts, moisture, etc. during long-distance transportation.
- Check whether the internal wires and connectors of the lamp are desoldered or loose.
- Check whether the electrical components of the lamp (such as power switch, transformer, ballast, capacitor, varistor, filter, power supply PCB board, motor control PCB board, etc.) are loose, short-circuited, burned out, etc.
- Some functions of the lamp cannot accept controller instructions
- Check whether the control device sends correct action instructions for these functions.
- Check whether the mechanical parts corresponding to these functions are loose or deformed.
- Check whether the motor sockets corresponding to these functions are loose or the corresponding driver chips are burned out.
- Check whether the motor wires corresponding to these functions are broken at the corners.
- Check whether the motors corresponding to these functions are damaged.

## 7. Fixture Cleaning

It is absolutely essential that the fixture is kept clean to ensure the maximum light-output and allow the fixture to function reliably throughout its life. The fixture must be cleaned regularly to avoid dust, dirt and smoke-fluid residues building up on or within the fixture. The cleaning frequency depends on the application environment. Clean the fixture immediately if the dust enters it to avoid damage to the optical lens due to excessive dust.

- A soft lint-free cloth moistened with any good glass cleaning fluid is recommended, under no circumstances should solvents be used.
- Always dry the parts carefully.
- Clean the external optical lens at least every 20 days.



### **CAUTION ! ! !**

**Disconnect from mains before starting maintenance operation.**

## 8. Duty exonerative and copyright protectio

- Light source belongs to consumption products, not within the scope of warranty.
- The manufacturer shall not bear any responsibility for any damage caused by failure to operate in accordance with this instruction.
- The manufacturer reserves the right of final interpretation for all information in this manual. For any questions, please refer to the official website.
- All the information in this manual shall not be copied without permission.
- The data contained in this statement are subject to change in the future without prior notice.