

LIGHT SKY[®]

FLY DRAGON LIGHTING EQUIPMENT CO.,LTD

SUPER SCOPE PRO

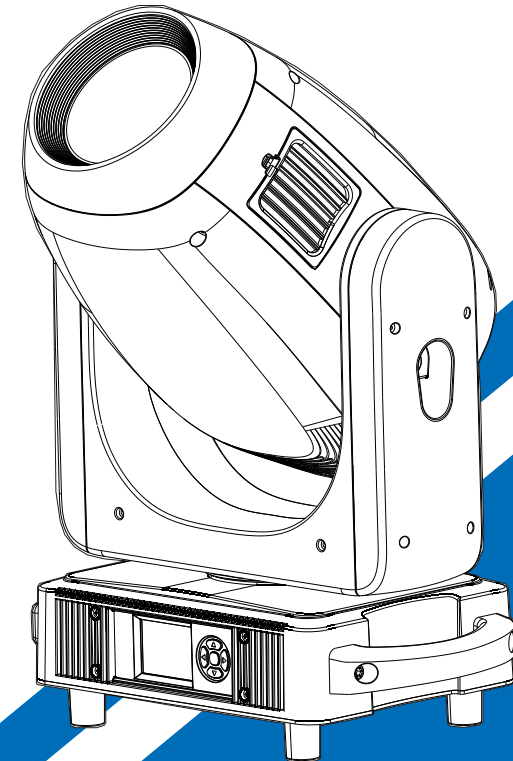

LIGHT SKY[®]

Tel:0086-20-61828288

Fax:0086-20-61828188 Pc:510800

Web:www.lightsky.com.cn

E-mail: flydragon@lightsky.com.cn

asia@lightsky.com.cn

asia01@lightsky.com.cn

india@lightsky.com.cn

europa@lightsky.com.cn

latinamerica@lightsky.com.cn

middle-east@lightsky.com.cn

american@lightsky.com.cn

Address: No. 43, Yunfeng Road, Xiuquan Street,
Huadu District, Guangzhou, China



LIGHT SKY[®]



WWW.LIGHTSKY.COM.CN

User Manual

Please read the instruction carefully before use

CONTENTS

1. Safety Instructions.....	2
2. Technical Specifications	5
2.1. Attachment And Size	7
3. Color/Gobo/Prism	9
4. Control Panel	10
5. Connection and control	11
5.1. Power supply connection	11
5.2. DMX 512 Connection.....	12
6. How To Set The Unit	13
6.1. Main Function.....	13
6.2. Channel Setting.....	15
6.3. Address Setting.....	15
6.4. DMX 512 Configuration	16
7. Electrical Connection Diagram	19
8. Troubleshooting.....	20
9. Fixture Cleaning.....	22
10. Duty exonerative and copyright protectio.....	22

Congratulations on choosing our company product! We thank you for your custom.

- ◆ Please keep in mind that this product, like other products of the company, adheres to the concept of people-oriented design and manufacture, and takes product quality as the foundation.
- ◆ We put the interests of customers first, and do our best to meet customer requirements.
- ◆ Please read this instruction manual carefully and keep it for future reference. In the case of fully understanding the product information, strictly abide by theUse the instruction manual to ensure that the product is installed, used and serviced correctly and safely.
- ◆ Our company is not responsible for any damage to lamps or other performance due to personal failure to follow the instructions during installation, use and maintenance.responsibility.
- ◆ Our company reserves the right to modify the manual at any time and without prior notice.

1.Safety Instructions



Please read the instruction carefully which includes important information about the installation, usage and maintenance.

WARNING

Please keep this User Manual for future consultation. If you sell the unit to another user, be sure that they also receive this manual.

The following symbols are used to identify important safety information on the product and in this manual:

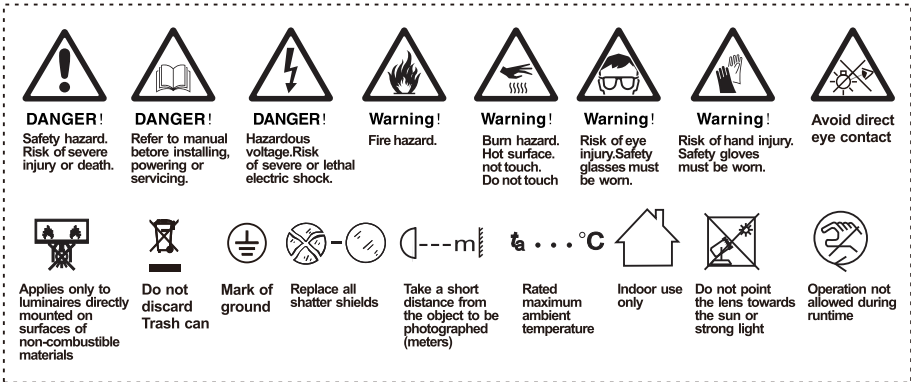

Important:

Damages caused by the disregard of this user manual are not subject to warranty.

The dealer will not accept liability for any resulting defects or problems.

- Unpack and check carefully to ensure that there is no transportation damage before using the unit.
- This product is for indoor use only. Use only in a dry location.
- Do install and operate by qualified operator.
- The light source in this luminaire should be replaced by the manufacturer or its service agent or a similarly qualified person, always cut off the power supply before replacing the light source.
- Do not allow children to operate the fixture.
- Use safety chain when fixing the unit. Handle the unit by carrying its base instead of head only.

- The unit must be installed in a location with adequate ventilation, at least 20cm from adjacent surfaces.
- Be sure that no ventilation slots is blocked, otherwise the unit will be overheated.
- Before operation, ensure that you are connecting this product to the proper voltage in accordance with the specifications in this manual or on the product's specification label.
- It's important to ground the yellow/green conductor to earth in order to avoid electric shock.
- Minimum ambient temperature Ta: 0°C. Maximum ambient temperature Ta: 40°C.
Do not operate this product at a lower or higher temperature.
- Do not connect the device to any dimmer pack.
- When the lamp is running, do not place combustible objects next to it. The shortest distance between the device and inflammable and explosive objects or materials is 0.5m.
- Make sure the power cord is not crimped or damaged; replace it immediately if damaged.
- Unit's surface temperature may reach up to 80°C. do not touch the housing bare-handed during its operation.
- Avoid any flammable liquids, water or metal from entering the unit. Once it happens, cut off the mains power immediately.
- Do not operate in a dirty or dusty environment. do clean the fixture regularly.
- Do not touch any wire during operation as there might be a hazard of electric shock.
- Avoid entanglement of the power cord with other wires.
- The minimum distance to objects/surface must be more than 3 meters.
- In the event of serious operating problem, stop using the unit immediately.
- Never turn on and off the unit time after time.
- The housing, the lenses, or the ultraviolet filter must be replaced if they are visibly damaged.
- Do not open the housing as there are no user serviceable parts inside.
- Do not attempt to operate this unit if it becomes damaged. do not attempt any repairs yourself. Repairs carried out by unskilled people can lead to damage or malfunction. Please contact the nearest authorized technical assistance center if needed.
- Disconnect this product from its power source before servicing.
- Do use the original packaging if the device is to be transported.
- Avoid direct eye exposure to the light source while the product is on.

- Do not operate this product if you see damage on the housing, shields, or cables. Have the damaged parts replaced by an authorized technician at once.

Installation:

The fixture should be fixed on the clamp. Always ensure that the unit is firmly fixed to avoid vibration and slipping off during operation. Ensure that the trussing or area of installation must be able to hold 10 times the weight without any deformation. Always install a safety cable that can hold at least 12 times the weight of the fixture when installing. Do install and operate by qualified operator. It must be installed in a place where there is out of the reach of people.

2. Technical Specifications

OPTICAL

- Light source: 450W white LED module
- Zoom range: 4°- 53°
- Optical lens: coated with high anti-reflection coating, diameter 133mm
- Color temperature: 6500K
- Color rendering index: $RA \geq 70$ / $RA \geq 90$ (cut into high rendering index filter)
- Illuminance: 26000 Lux@10m
- Luminous flux: 21000 Lm
- Light source lifespan: $\geq 20000H$

COLOR

- CMY infinite color mixing
- CTO color temperature linear adjustment (3000K-6500K)
- 5 color chips + high-resolution finger + white light, can realize two-way color rainbow, two-color step-by-step gradient (linear movement), two-way rotation of color wheel, random color mode.

PATTERN

- Rotating gobo wheel: 7 kinds of glass patterns + white circle, pluggable and replaceable, can realize rotation, flowing water, shaking effects, the outer diameter of the gobo is 22.9mm, and the inner diameter of the gobo is 15mm.
- Effect disc (water texture)+CTO color temperature linear adjustment, which can achieve flowing and shaking effects.
- Eight-direction cutting: 4 pieces of gratings can achieve fast and smooth cutting, and the eight cutting directions and angles can be controlled separately, each single piece can achieve complete light closure, and the entire cutting module can be rotated $\pm 45^\circ$.

EFFECT

- Prism: 4 prism, capable of bidirectional rotation.
- Soft light effect: adjustable independent soft light effect.
- With electric aperture, 5-100% linear adjustment, with macro function and multi-effect change.
- Electronic dimming, 0-100% linear dimming, uniform light spot
- Electronic strobe speed is 1-25 times/second
- LED refresh rate: 1000Hz ~ 25KHz

CONTROL

- Control channel: 33CH、36CH
- Protocol: standard DMX512 , RDM , ArtNet
- Data connection: three-core or five-core signal input/output
- Display: LCD liquid crystal screen

SOFTWARE

- Software upgrade via USB or DMX interface
- Intelligent temperature control to ensure LED life

X, Y AXIS MOVEMENT

- X axis: 540° 8bit/16bit precision scanning
- Y axis: 270° 8bit/16bit precision scanning

POWER AND POWER

- Input voltage rangr: AC 100-240V ~ 50/60Hz
- Maximum power:520W
- Power factor: 0.98

SIZE AND WEIGHT

- size: 442mm×262mm×648mm
- N.W: 26.3kg
- Carton packing (default): 495mm×365mm×755mm G.W: 32.1kg (include foldable clamp)
- Flycase Size(2 sets): 730×575×845mm G.W: 95.3 Kg

OTHER

- Protection class: Ip20
- Working environment: 0°C ~ 40°C
- Maximum surface temperature of the lamp body: 80°C
- Maximum lamp current: 5.2A/110V; 2.6A/220V
- Optional accessories: FAST LOCK

APPROVALS

- The product implementation standard: GB 7000.1-2015 GB7000. 217-2008
- Approved certifications: CE、RoHs
- The product complies with the following EU directives:
- Low Voltage Directive 2014/35/EU . EMC Directive 2014/30/EU

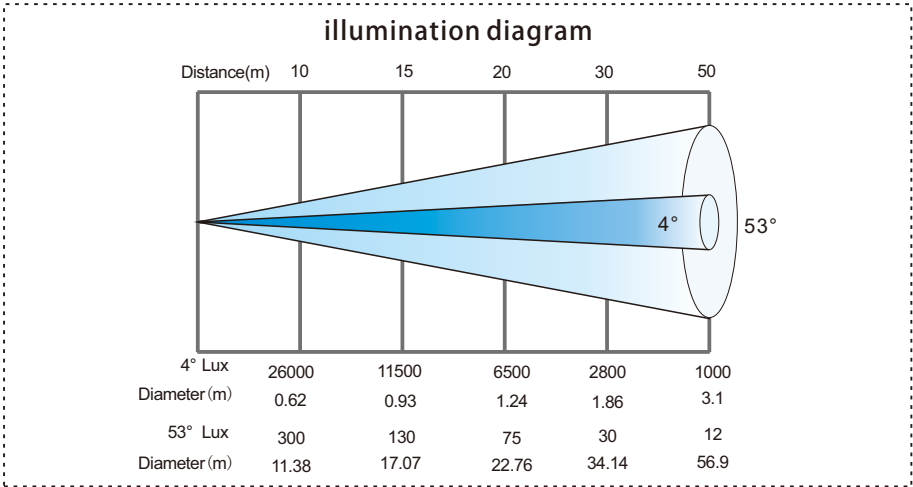

2.1.Attachment And Size

Attachment contents-Fig.1

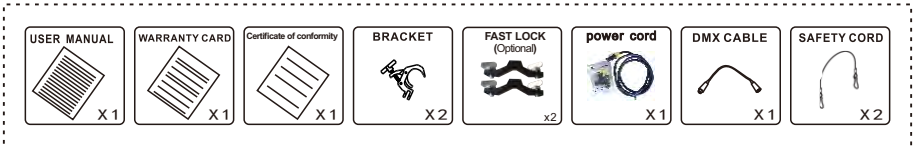

Size-Fig.2

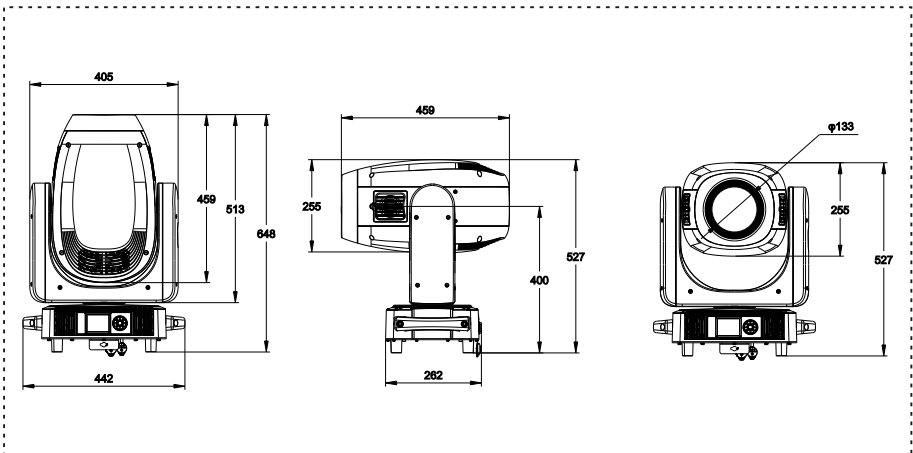

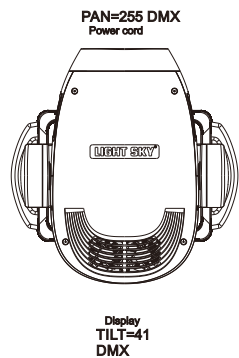
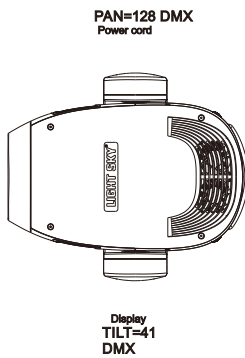
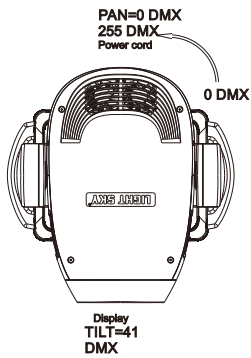
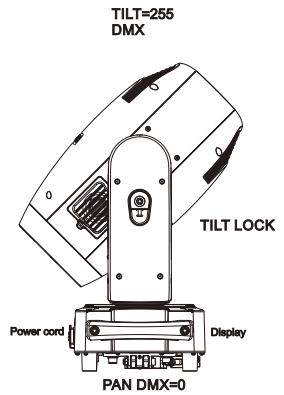
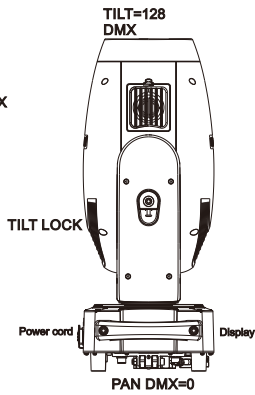
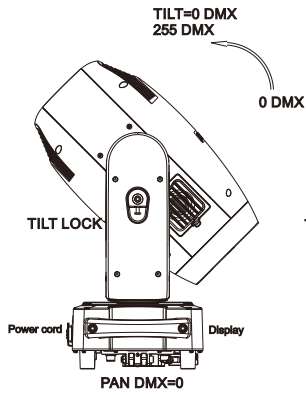

3. Color/Gobo/Prism

CMY-color wheel

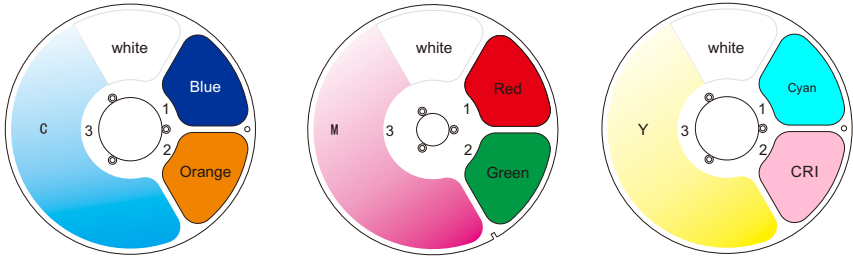

Pattern-Effect disc

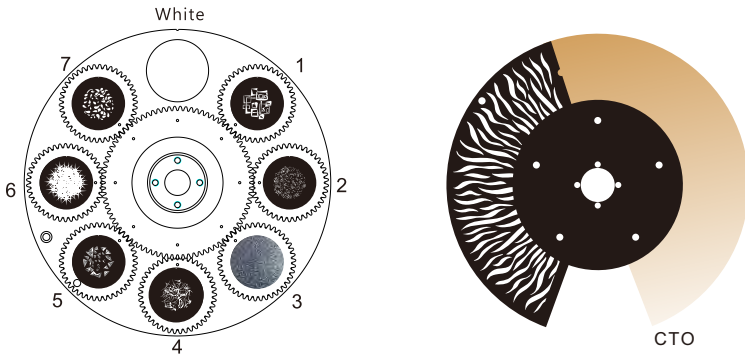

Prism

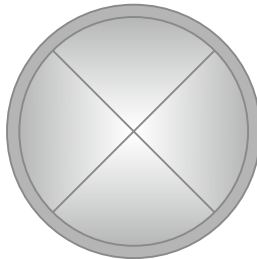

4. Control Panel

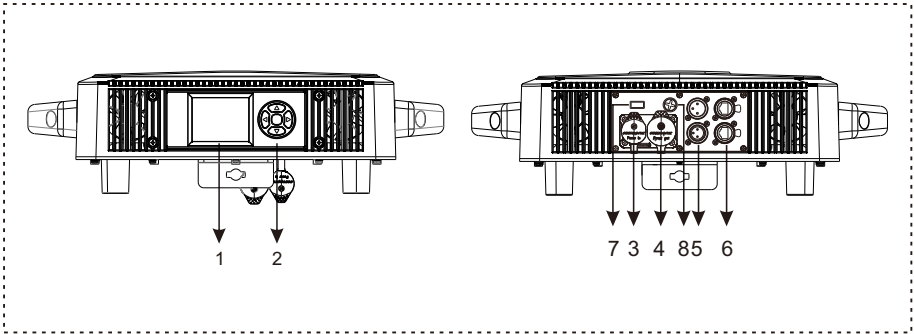

1. Display: To show the various menus and the selected function.
2. Button:

●	OK confirmation key
▲	UP
▼	DOWN
◀	To the left
▶	To the right

3. Socket version power input: connect the power supply.
4. Power output: Connect the lamp power output adapter.
5. DMX input/output: Used for DMX512 connection, use 3/5 core XLR signal cable to connect console and lamps, And input/output DMX signal.
6. Art-net: The information of the lamp can be transmitted to the main controller through the network cable, and the lamp can be controlled through RJ45 (optional).
7. Firmware upgrade: Used to upgrade the fixture's firmware.
8. FUSE: 10A.

5.Connection and control

5.1.Power supply connection

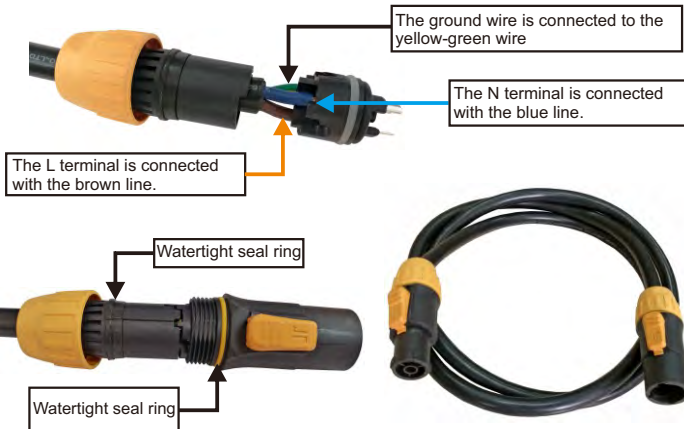
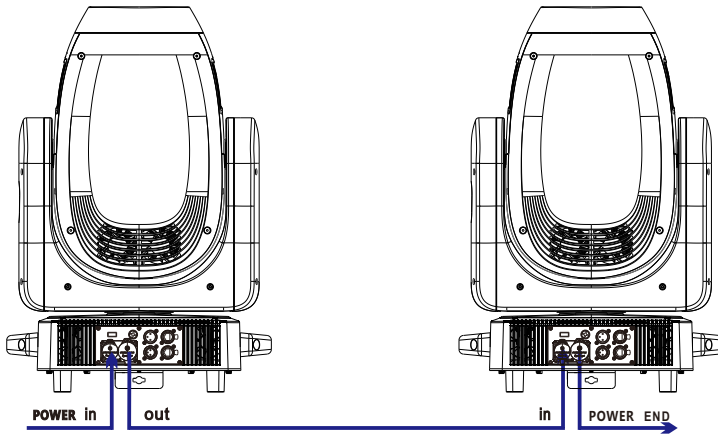

- The bus connecting the power supply must be installed by a qualified professional technician.
- After completing all the above operations and ensuring that it is installed, you can power on the lamp to operate.

5.2.DMX 512 Connection

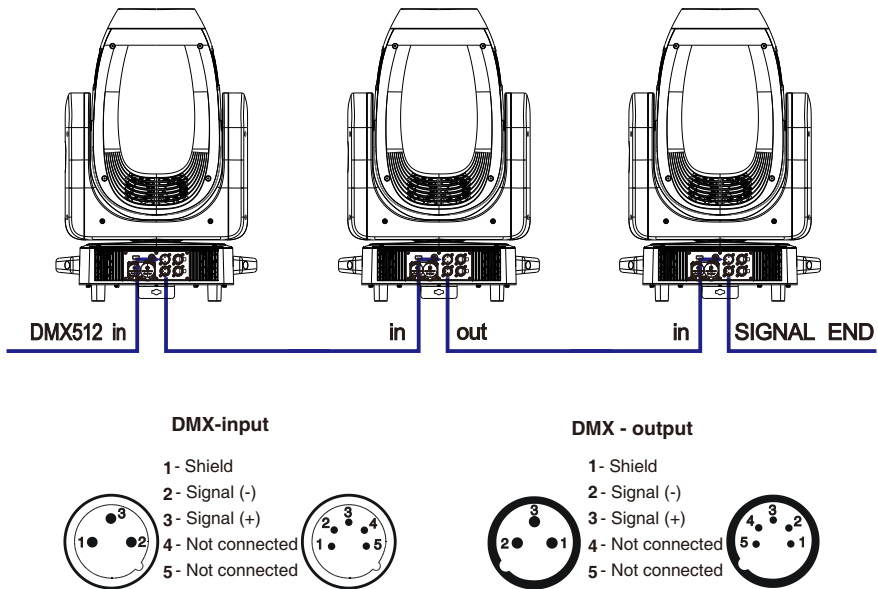

1. At last unit, the DMX cable has to be terminated with a terminator. Solder a 1200hm 1/4W resistor between pin 2(DMX-) and pin 3(DMX+) into a 3-pin XLR-plug and plug it in the DMX-output of the last unit.
 2. Connect the unit together in a "daisy chain" by XLR plug cable from the output of the unit to the input of the next unit. The cable cannot be branched or split to a "Y" cable. DMX 512 is a very high-speed signal. Inadequate or damaged cables, soldered joints or corroded connectors can easily distort the signal and shut down the system.
 3. The DMX output and input connectors are pass-through to maintain the DMX circuit, when one of the units' power is disconnected.
 4. Each lighting unit needs to have a DMX address to receive the data by the controller. The address number is between 1-512.
 5. The end of the DMX 512 system should be terminated to reduce signal errors.
 6. 3 pin XLR connectors are more popular than 5 pins XLR.
- 3 pin XLR: Pin 1: GND, Pin 2: Negative signal (-), Pin 3: Positive signal (+)
 5 pin XLR: Pin 1: GND, Pin 2: Negative signal (-), Pin 3: Positive signal (+), Pin4, Pin5 not used.

6.How To Set The Unit

6.1.Main Function

Turn on the fixture, press the OK button to enter the menu mode, use the UP/DOWN buttons to find the menu, when the preset menu is shown on the display, press the OK button to confirm, use the UP/DOWN buttons to select a submenu, then press the OK button to save Settings, use the left button to return to the previous menu. The main functions are as follows:

Main menu	I menu	II menu	III menu	IV menu
DMX SETTING	Address	→ 1-512		
	→ Channel mode	→ Standard (33)		
		→ Extended (36)		
	Input mode	→ DMX 512		
		→ Artnet		
NoDMX State	→ Hold			
Info	Fixture times	→ Power on time	0 - 99999H	
		→ LED on time	0 - 99999H	
		→ All time	0 - 99999H	
	Temperatures	→ LED TEMP		
		→ Drive TEMP		
	RDM info	→ UID:0x388XXXXXXXX		
	→ DMX live	→ 1. Pan	0 - 255	
		→ 2. Pan fine	0 - 255	
		→ 3.	0 - 255	
	Version info	→ Display	VX.XXX	
		→ Pan/Tilt	VX.XXX	
		→ LED module	VX.XXX	
		→ Gobo module	VX.XXX	
		→ Blade module	VX.XXX	
		→ Zoom module	VX.XXX	
	Fan Info	→ InFan Voltage		
		→ OutFan Voltage		
		→ InFan1		
		→ InFan2		
		→ OutFan1		
→ OutFan2				
→ GoboFan				
→ FrameFan				
→ HeadFan				
Person	Pan/Tilt	→ Pan invert	OFF	
			ON	
		→ Tilt invert	OFF	
			ON	
	Fan mode	→ Hight Brightness		
		→ Silent		
		→ Super Silent		
	Display	→ Language	English	
			Chinese	
		→ Backlight time	Always	
			Auto (30S)	
		→ Intensity	0 - 100	
	Rotation		Normal	
			Rotate 180	
			Auto	
	Art-Net	→ IP Address	xxx.xxx.xxx.xxx	
		→ Mask Address	xxx.xxx.xxx.xxx	
		→ Net Address	xxx.xxx.xxx.xxx	
		→ Sub Net Address	xxx.xxx.xxx.xxx	
		→ Universe Address	xxx	
Dimmer Curve	→ Linear			
	→ Square 1(Default)			
	→ Square 2			
	→ SCurve			
Led Preq Set	→ 1000 Hz (Default)			
	→ 3600 Hz			
	→ 7200 Hz			
	→ 25000 Hz			

Main menu	I menu	II menu	III menu	IV menu		
Manual	Manual Control	1. Pan	0 - 255			
		→ 2. Pan fine	→ 0 - 255			
		3.	0 - 255			
	Reset	Total reset				
		Pan/Tilt reset				
		Gobo reset				
		→ Color reset				
		Profile reset				
		Focus reset				
		Effect reset				
Test	Test all	Testing				
	→ Test pan/tilt	→ Testing				
	Test effects	Testing				
Service	Fixture state	Memory IC	OK/Reset/Error			
		Angle Sensor	OK/Reset/Error			
		Pan Encoder	OK/Reset/Error			
		Tilt Encoder	OK/Reset/Error			
		Pan	OK/Reset/Error			
		Tilt	OK/Reset/Error			
		Zoom	OK/Reset/Error			
		Focus	OK/Reset/Error			
		Cyan	OK/Reset/Error			
		→ Magenta	→ OK/Reset/Error			
		Yellow	OK/Reset/Error			
		RotGobo	OK/Reset/Error			
		GoboRot	OK/Reset/Error			
		Animation	OK/Reset/Error			
		Frame	OK/Reset/Error			
		FrameRot	OK/Reset/Error			
		Iris	OK/Reset/Error			
		Prism	OK/Reset/Error			
		Frost	OK/Reset/Error			
	Adjust	→ Pan	→ 0 - 255			
		Tilt	→ 0 - 255			
		0 - 255			
	Factory	Factory Reset	→ YES / NO			
		Reset timers	Reset power on timers	→ YES/NO	YES/NO	
			Reset led timers	→ YES/NO	YES/NO	
			Reset all timers	→ YES/NO	YES/NO	
		Update	Simple update	Display	→ Pan/Tilt	Display
				...	→
			Whole update	ALL	→ ALL	ALL
				Display	→ Pan/Tilt	Display
		Logo select	...	→	
			...	→	
	...		→		
	...		→		

6.2.Channel Setting

Enter the MENU menu, select the Personal Settings function, select the channel mode, press the OK button to confirm, you can use the up and down keys to select:33 channels (default), 36channels, Press the OK key to enter the selection confirmation and return to the previous menu.

6.3.Address Setting

Enter MENU, select the DMX setting function, select the address code setting, press the OK button to confirm, the current DMX address will be displayed on the display. Use the up/down buttons to select addresses 001~512, and press the OK button to save. Press the OK button to return to the previous menu.

Please refer to the following diagram to address your DMX512 channel for the first 4 units.

Channel mode	Unit 1 Address	Unit 2 Address	Unit 3 Address	Unit 4 Address
33 CH	1	34	67	100
36 CH	1	37	73	109

6.4.DMX 512 Configuration

Please control the fixture by referring to the configurations below

33 Channel	36 Channel	DMX	Function	Note
1	1	0--255	Pan positioning	
2	2	0--255	Fine Pan positioning	
3	3	0--255	Tilt positioning	
4	4	0--255	Fine Tilt positioning	
/	5	0--255	Speed pan/tilt	
5	6	0--9 10--19 20--29 30--39 40--49 50--59 60--69 70--79 80--89 90--99 100--109 110--119 120--129 130--139 140--149 150--159 160--169 170--177 178--185 186--193 194--199 200--204 205--209 210--214 215--219 220--229 230--239 240--255	DeviceSet(Hold 3s) No function Fan high speed Fan auto speed Fan slow speed Reset Pan&Tilt Reset CMY Reset Gobo Reset Frame Reset Head Reset other(except P&T) Reset All No function No function Pan invert on Pan invert off Tilt invert on Tilt invert off LED frequency 1kHz LED frequency 3.6kHz LED frequency 7.2kHz LED frequency 25kHz Dimmer curve linear Dimmer curve square Dimmer curve inv--square Dimmer curve "S" Dimmer fast Dimmer smooth No function	
6	7	0--255	Cyan	
7	8	0--255	Magenta	
8	9	0--255	Yellow	
9	10	0--5 6--23 24--41 42--59 60--77 78--95 96--113 114--133 134--194 195--255	Virtual ColorWheel CMY enable Red Green Blue Orange light blue CRI CMY enable virtual Colorwheel CW slow to fast virtual Colorwheel CCW fast to slow	
		0--9 10--19 20--29 30--39 40--49	RotgoboWheel Open RotGobo1 RotGobo 2 RotGobo 3 RotGobo 4	

33 Channel	36 Channel	DMX	Function	Note
10	11	50--59 60--69 70--79 80--87 88--95 96--103 104--111 112--119 120--127 128--135 136--139 140--194 195--249 250--255	RotGobo 5 RotGobo 6 RotGobo 7 RotGobo1shake,slow to fast RotGobo2shake,slow to fast RotGobo3shake,slow to fast RotGobo4shake,slow to fast RotGobo5shake,slow to fast RotGobo6shake,slow to fast RotGobo7shake,slow to fast Open RotGoboWheel CW fast to slow RotGoboWheel CCW slow to fast Random Gobo	
11	12	0--127 128--189 190--193 194--255	GoboRot GoboRot indexing 0°-- 360° RotGobo CW fast to slow Stop RotGobo CCW slow to fast	
12	13	0--255	CTO	
13	14	0 --127 128--255	Effect wheel Animation index Animation rotation	
14	15	0--255	BladeA position1	
15	16	0--255	BladeA position2	
16	17	0--255	BladeB position1	
17	18	0--255	BladeB position2	
18	19	0--255	BladeC position1	
19	20	0--255	BladeC position2	
20	21	0--255	BladeD position1	
21	22	0--255	BladeD position2	
22	23	0--255	Frame Rot	
23	24	0 --10 11--20 21 --30 31 --40 41 --50 51 --60 61 --70 71 --80 81 --255	Framing Macro No function Square Rectangle Triangle Trapezoid Sector Semi-circle Parallelogram No function	
24	25	0--127 128--159 160--191 192--255	Iris Iris Indexing Slow close fast open ; slow--fast Fast close slow open; slow--fast Slow close slow open ;slow--fast	
		0--9 10--63 64--127	Prism&PrismRot Prism out Prism In & indexing Forwards prism rotation from slow to fast	

33 Channel	36 Channel	DMX	Function	Note
25	26	128--191 192--207 208--223 224--239 240--255	Backwards prism rotation from fast to slow prism flickered 90° prism flickered 180° prism flickered 270° prism flickered 360°	
26	27	0--255	Frost	
27	28	0--255	Focus8bit	
/	29	0--255	FocusFine16bit	
28	30	0--255	Zoom8bit	
/	31	0--255	ZoomFine16bit	
29	32	0--9 10--19 20--68 69--79 80--128 129--139 140--188 189--255	Strobe Strobe closed Strobe open Normal strobe effect slow to fast Strobe open Pulse strobe Strobe open Random strobe Strobe open	
30	33	0--255	Dimmer	
31	34	0--255	Dimmer Fine	
32	35	0--127 128--158 159--190 191--225 226--255	Auto Focus Auto Focus Disable 10m Auto Focus Enable 15m Auto Focus Enable 20m Auto Focus Enable 30m Auto Focus Enable	
33	36	0--255	Auto FocusFine	

7. Electrical Connection Diagram

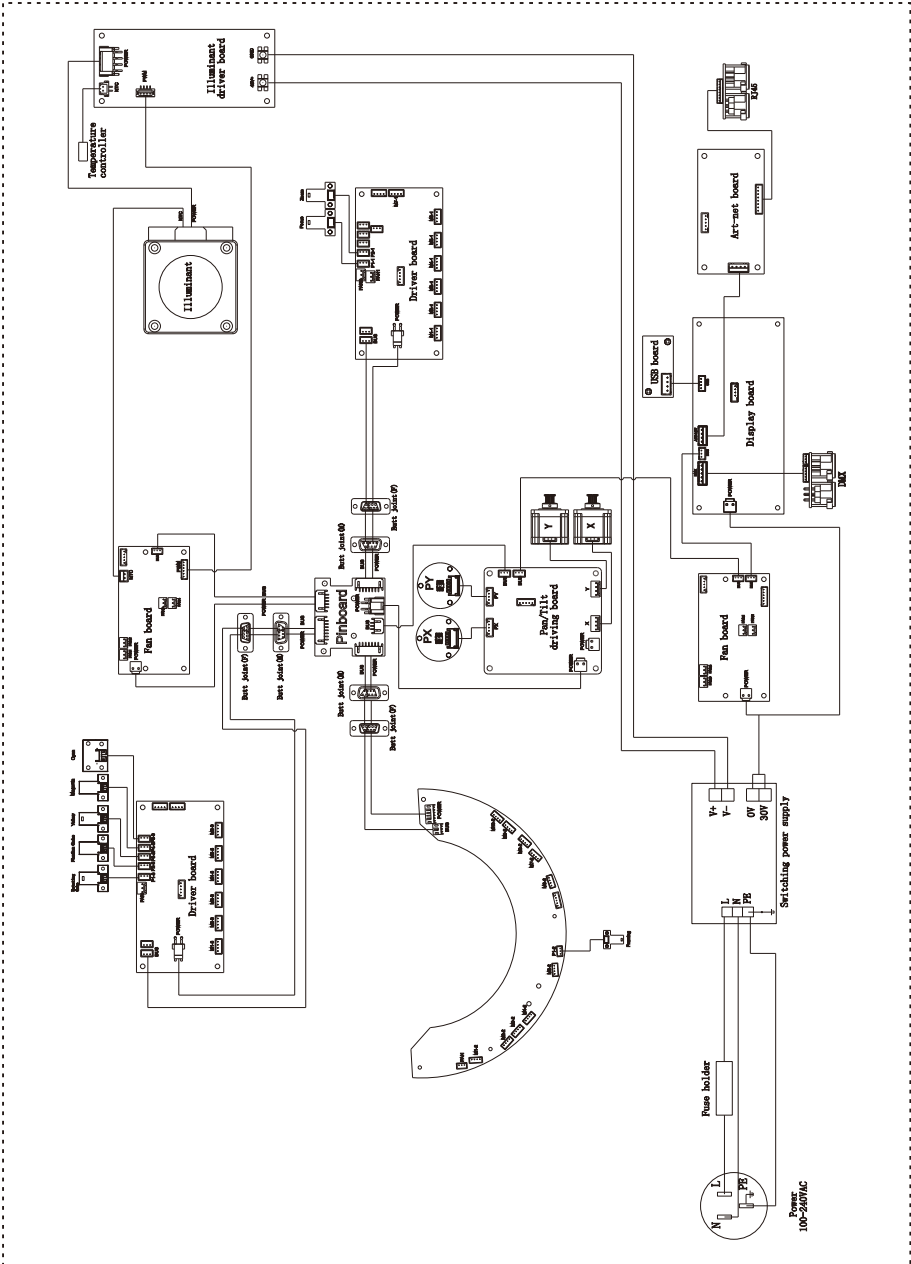

8. Troubleshooting

The following are common faults of lamps and corresponding solutions. Faults that cannot be repaired by yourself should be handled by professionally qualified personnel. Disconnect the power supply to the lamp during maintenance!

● The light source is not bright

- Check that a suitable light source is installed for the luminaire.
- Check whether the power supply connection of the lamp or the control switch is in poor contact.
- Check whether the light source has reached the end of its service life or is damaged, and replace it with a high-quality light source of the same specification.
- Measure whether the power supply is insufficient.
- Check whether the light source has not cooled down completely due to abnormal operation. Let the lamp cool down for more than 15 minutes to allow the light source to cool down. After returning to the normal start-up range, turn the power on again and it can be used normally.
- Check whether the DMX512 controller sends a command to turn on the light source.
- Check whether the light source and trigger circuit are disconnected or defective.
- Check whether the wiring terminals on the internal trigger are in poor contact and tighten the plug.
- Check the "Fan Speed and Voltage" in the "Basic Information" menu to see if the speed of FAN1/FAN2/FAN3 is above 500RPN. If it is below 500RPM, the light source will not light up. Replace the fan with the same specification.
- Check whether the over-temperature protection temperature switch inside the lamp is damaged. Go to the menu "Basic Information" and select "Equipment Temperature" to check - whether the temperature measuring plate shows that the temperature is too high or there is no temperature display.

● The beam appears dim and uneven

- The light source may have reached the end of its service life and does not emit enough light. Replace it with a light source of the same specification.
- Check whether there is dust accumulated in the optical part and clean it.
- Measure whether the power supply is insufficient.
- Finely adjust the screw device used to change the height of the lamp until the ideal light is achieved. Enter the menu "Service Options" and select "Calibration" to enter color and pattern adjustment, which can be adjusted to the center.

● The projected image is blurry

- Check whether the DMX512 controller channel value corresponding to the electronic focus system is suitable for the current projection distance.
- Check whether the mechanical part of the focusing system is stuck, remove the dust and add antifreeze and temperature-resistant lubricating oil.

● The light source of the lamp works intermittently

- Check whether the fan is running normally or is blocked by dust and paper debris.
- Check whether the inlet and outlet cooling air vents are blocked by dust.
- Check whether the lamp has reached the end of its service life.

- Check whether the power supply is insufficient, and whether the power switch and wiring are in poor contact or aging.

- Check whether the over-temperature protection temperature switch inside the lamp is damaged.

● **Although it emits light, the lamp does not accept instructions from the controller**

- Check whether the digital start address value and function options of the lamp are correct.

- Check whether the connection of the communication control line is correct. The communication line is too long or has been interrupted.

- Check whether the control equipment fails and whether the signal amplifier connected in series fails.

- Check whether the communication line is too long or if other devices interfere with each other.

- Optimize wiring, shorten the length of control signal lines, and route high-voltage and low-voltage lines separately

- Add signal amplifier isolator.

- The signal line is made of high-quality shielded twisted pair (impedance characteristic is 75Ω), and the signal terminal resistor is connected at the end of the lamp.

- Check that the circuit board communication IC or CPU is burned out because the bulb performs an abnormal operation when it is not completely cooled, causing the instantaneous ultra-high voltage leakage generated by the trigger, and replace the PCB board.

● **The lamp cannot be started**

- Check whether the power supply parameters match the lamps.

- Check whether the fuse at the light fixture's power input is blown.

- Check that the lamp has poor contact or falls off due to extrusion deformation, vibration of internal parts, moisture, etc. during long-distance transportation.

- Check whether the internal wires and connectors of the lamp are desoldered or loose.

- Check whether the electrical components of the lamp (such as power switch, transformer, ballast, capacitor, varistor, filter, power supply PCB board, motor control PCB board, etc.) are loose, short-circuited, burned out, etc.

● **Some functions of the lamp cannot accept controller instructions**

- Check whether the control device sends correct action instructions for these functions.

- Check whether the mechanical parts corresponding to these functions are loose or deformed.

- Check whether the motor sockets corresponding to these functions are loose or the corresponding driver chips are burned out.

- Check whether the motor wires corresponding to these functions are broken at the corners.

- Check whether the motors corresponding to these functions are damaged.

● **During operation, the x or Y direction of the lamp does not move normally**

- Click the previous step to check one by one.

- Check whether the corresponding drive belts in the X and Y directions of the lamp are detached or broken.

- Check whether the data feedback receiver (photoelectric sensor) corresponding to the X and Y directions in the lamp is damaged.

- Restart the computer and reset it once.

9. Fixture Cleaning

It is absolutely essential that the fixture is kept clean to ensure the maximum light-output and allow the fixture to function reliably throughout its life. The fixture must be cleaned regularly to avoid dust, dirt and smoke-fluid residues building up on or within the fixture. The cleaning frequency depends on the application environment. Clean the fixture immediately if the dust enters it to avoid damage to the optical lens due to excessive dust.

- * A soft lint-free cloth moistened with any good glass cleaning fluid is recommended, under no circumstances should solvents be used.
- * Always dry the parts carefully.
- * Clean the external optical lens at least every 20 days and the internal optical lens every 30 days.

CAUTION ! ! !

Disconnect from mains before starting maintenance operation.

10. Duty exonerative and copyright protectio

- * Light source belongs to consumption products, not within the scope of warranty.
- * The manufacturer shall not bear any responsibility for any damage caused by failure to operate in accordance with this instruction.
- * All the information in this manual shall be interpreted by the manufacturer.
- * All the information in this manual shall not be copied without permission.
- * The data contained in this statement are subject to change in the future without prior notice.